



AMERICAN SPECIALTIES, INC.
 441 Saw Mill River Road, Yonkers, NY 10701
 (914) 476.9000 • (914) 476.0688
 www.americanspecialties.com

MODEL №: 0362

ISSUED: 2-07

REVISED: 30 NOV 2018

SURFACE MOUNTED STAINLESS STEEL AUTOMATIC LIQUID SOAP DISPENSER

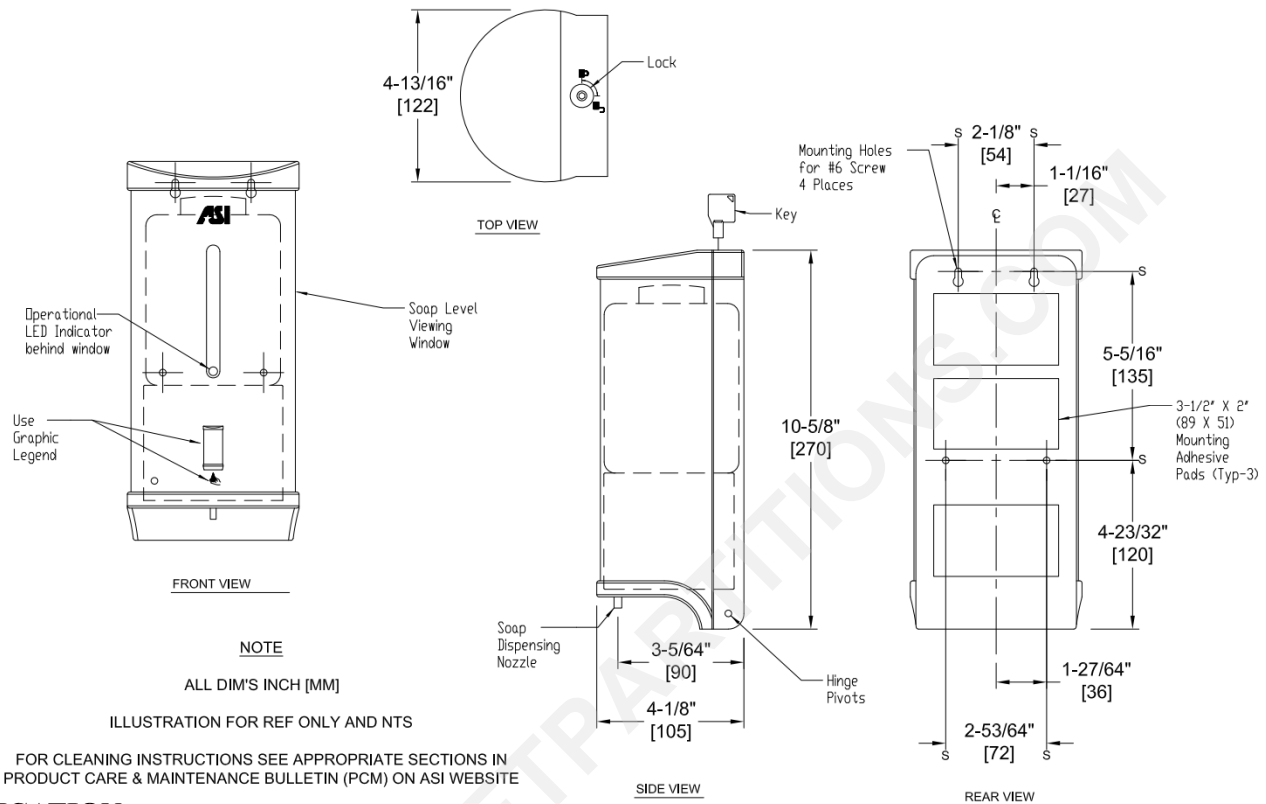

SPECIFICATION

Surface Mounted Stainless Steel Automatic Liquid Soap Dispenser shall hold and dispense liquid and lotion soaps within the pH range of 7 ± 1.5 and within the viscosity range of 2000~5000 cP (mPa•s) and a capacity of 900 ml (30 oz) using the refillable soap cartridge provided. Dispenser body shall be fabricated of alloy 18-8 stainless steel, type 304 with black high-impact ABS plastic top door, bottom plate and concealed gray high-impact ABS plastic back plate comprising a swing-open body secured with a top mounted lock which is opened with special barrel security key provided. All exposed stainless steel surfaces shall be either satin finish or matte black (add suffix -41). Dispenser shall be powered by four (4) AA-size (1.5 V) batteries (not supplied) and shall operate automatically from IR sensor that shall activate soap dispensing when hands are placed in sensor zone. Adjustable sensor detection range shall be preset at $2-3/8"$ [60] \pm $1-1/2"$ [38]. An indicator LED shall provide status notification of battery condition and user sensor detection. Unit shall dispense a volume of .034 fl oz to .051 fl oz (1 ml to 1.5 ml) of soap during each activation. A tamper resistant soap level-viewing window shall be provided. An Owner's Manual shall be provided with unit in carton.

Surface Mounted Stainless Steel Automatic Liquid Soap Dispenser shall be Model № 0362 (add -41 for matte black) of American Specialties, Inc., 441 Saw Mill River Road, Yonkers, New York 10701-4913

INSTALLATION

Surface mount unit to wall or partition with four (4) No 6 x 15/16" (M3.5 x 24) self-threading Philips pan head screws (supplied) into dry wall anchors (provided) through concealed mounting holes provided, or use self-adhesive pads (supplied) to mount unit to mirror. Recommended installation height for general utility is 42" [1067] to 46" [1168] AFF to bottom of unit. For compliance with 2010 ADA Accessibility Standards install unit so that bottom of unit is no higher than 48" [1219] MAX AFF. Mount unit with bottom 7-7/8" [200] minimum above non-metallic washbasins or countertops and 11-13/16" [300] above stainless steel washbasins or countertops. Installation and Operation Instructions (№ 0610241228) and a mounting template (№ 0610160837) are provided with unit in carton.

OPERATION

Soap is automatically dispensed when hands are placed in sensor zone. Unit is reloaded by unlocking lock with special key (supplied), swinging open dispenser body and removing and refilling or replacing disposable internal soap container. Soap dispenser will continue to feed properly until empty. Tank supply is replenished manually on a cycle determined by maintenance needs. Batteries are replaced yearly or as required for heavy duty operation. See OM for full details.