



**AMERICAN SPECIALTIES, INC.**  
 441 Saw Mill River Road, Yonkers, NY 10701  
 (914) 476.9000 • (914) 476.0688  
 www.americanspecialties.com

**MODEL №:** 9013

**ISSUED:** 4-04

**REVISED:** 30 July 2014

## RECESSED STAINLESS STEEL BABY CHANGING STATION

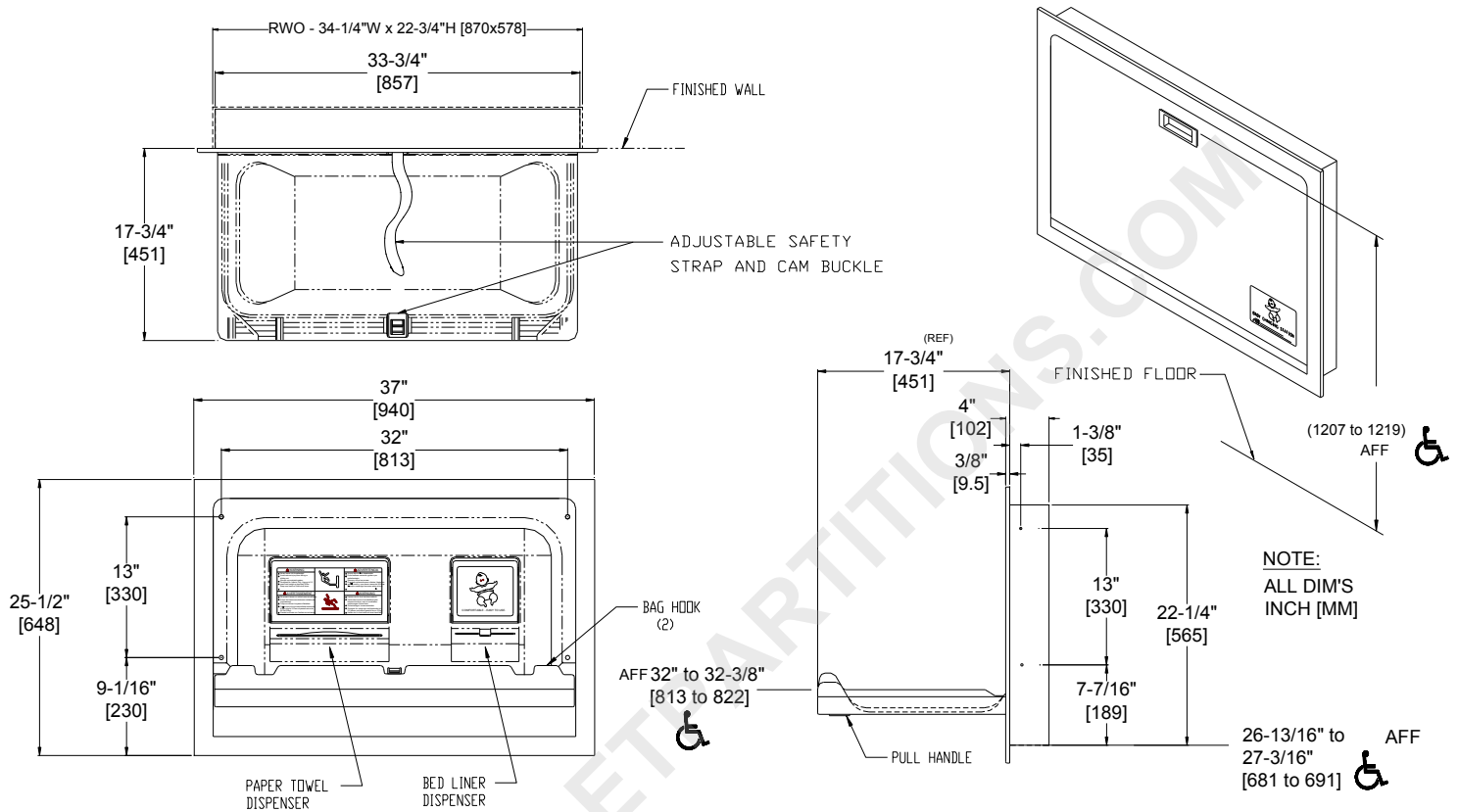

### SPECIFICATION

Recessed Baby Changing Station door, flange and cabinet shall be type 304 stainless steel, all welded construction. All exposed surfaces shall be polished to a satin finish. The door shall be 16 gauge (1.6) and the flange and cabinet shall be 18 gauge (1.3). The changing table shall be equipped with a rounded contoured pull handle and shall have a concealed damped gas spring to assist user in opening and closing unit with one hand. The bed liner shall be light gray, high impact plastic with a smooth finish for easy cleaning. The liner shall be shaped to cradle a child's body and shall be equipped with an adjustable two-part child protection safety strap and cam buckle adjustable with one hand. Unit shall include two bag hooks, bed liner dispenser, and a C-fold towel and multi-fold towel dispenser which can easily be converted to a multi-fold towel dispenser that needs no adapters. Unit shall have a minimum holding capacity of 400 lbs. (181.4 kg). The strength of the supporting wall and hardware must be adequate to support the rated load. Unit shall provide graphic and instructions in 4 languages. Unit shall comply with ASTM F-2285, G-21, G-22 and ANSI Z535 and shall be warranted for (5) years against defects in material or workmanship.

**Recessed Stainless Steel Baby Changing Station shall be Model No 9013 as manufactured by American Specialties, Inc. 441 Saw Mill River Road Yonkers, New York 10701-4913**

### INSTALLATION

Provide rough wall opening 34-1/4" (870) wide x 22-3/4" (578) high x 3-3/4" (95) minimum depth from face of finished wall. Mount unit in wall opening using either four (4) №10 x 1-1/2" (38) long self-tapping screws through side holes or four (4) 3/8" x 2" (Ø10 x 51) lag screws (or other fasteners appropriate for wall conditions) through mounting holes in rear wall of cabinet. Use washers and snap covers provided. For compliance with 2010 ADA Accessibility Standards, install unit so that top edge of changing table is 32" to 32-3/8" (813 to 822) above finished floor (AFF). See installation instructions packed with unit.

### OPERATION

Pull down changing table is counterbalanced with a damped gas spring and can be opened or closed with one hand by grasping pull handle. Secure the child in place by using child protection safety strap. The safety strap and cam buckle are assembled by sliding the safety strap into the cam buckle until it is snug on child. Tighten or loosen the strap by pulling the strap end through and clamping the buckle. To unbuckle the strap simply lift the buckle lever.

Accessory Specialties

AMERICAN DISPENSER

Desert Ray Products

WITROUS INC.