

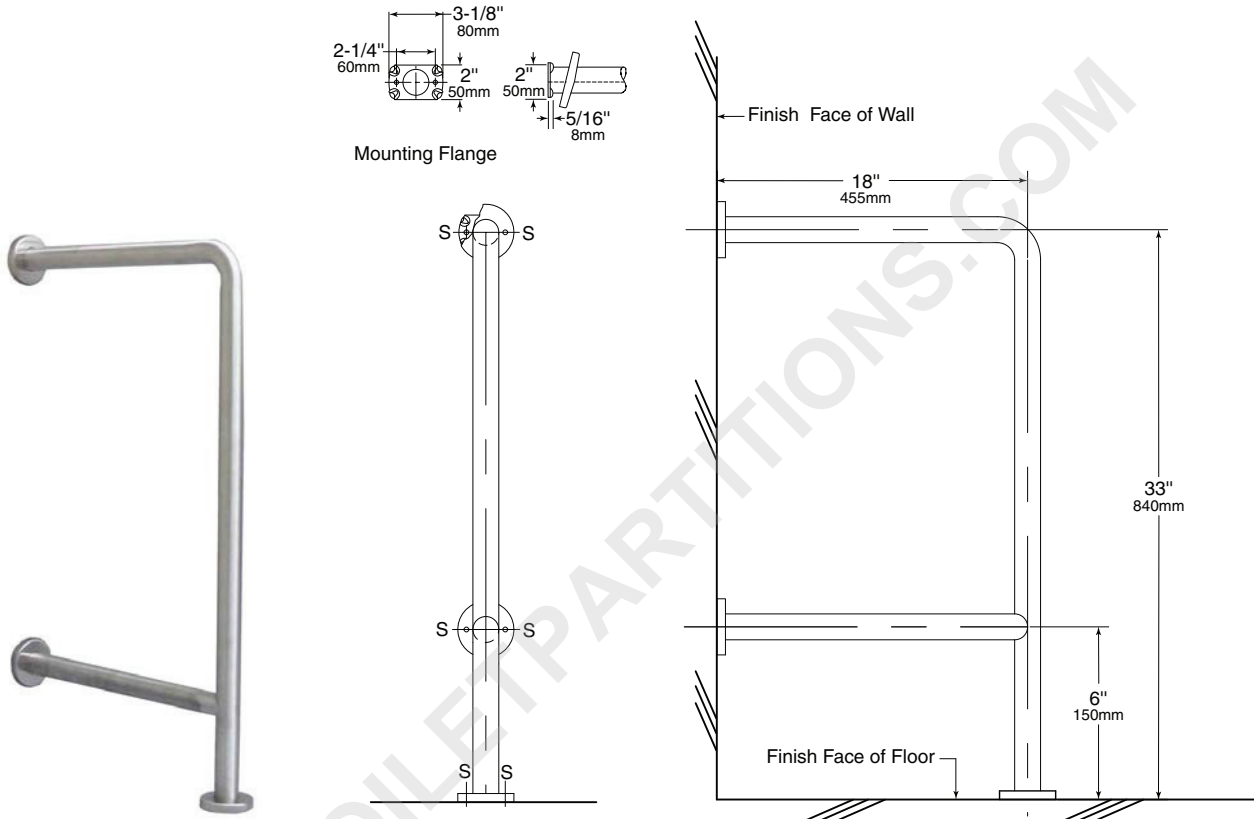

Technical Data

1½" (38mm) DIAMETER STAINLESS STEEL DRINKING FOUNTAIN GRAB BAR

819298



MATERIALS:

Grab Bar — 18-8 S, type-304, 18-gauge (1.2mm) stainless steel tubing with satin finish. 1-1/2" (38mm) outside diameter. Ends are heliarc welded to flanges.

Concealed Mounting Flanges — 18-8 S, type-304, 1/8" (3mm) thick, stainless steel plate; end flanges 2" x 3-1/8" (50 x 80mm) with two holes for attachment to wall and to floor.

Snap Flange Covers — 18-8 S, type-304, 22-gauge (0.8mm) drawn stainless steel with satin finish. 3-1/4" (85mm) diameter x 1/2" (13mm) deep. Each cover snaps over mounting flange to conceal mounting screws.

STRENGTH:

Grab bar can support loads in excess of 250 pounds (113kg) if properly installed, complying with barrier-free accessibility guidelines (including ADAAG in the U.S.A.) for structural strength.

Warning: Grab bars are no stronger than the anchors or walls to which they are attached and therefore, must be firmly secured in order to support the loads for which they are intended.

continued . . .

INSTALLATION:

Provide concealed anchor device or backing as specified or required in accordance with local building codes before wall is finished. Use the grab bar as a template to ensure accurate installation. Fasten concealed mounting flanges to anchor device or backing with two screws in each flange. Snap flange covers over each mounting flange to conceal mounting screws. Concealed anchor devices and mounting screws are not included with Bobrick grab bars and must be specified as an accessory.

Important Notes:

1. **Mounting Kits** — Bobrick has a selection of mounting screws and fasteners available for different types of installations; **one Bobrick mounting kit is required for each flange.**

Mounting Kit No.	Description
252-30	Consists of (3) #14 x 2½" type-304 stainless steel, Phillips round-head, sheet-metal screws.
2521-30	Consists of (3) 1/4–20 x 3½" type-304 stainless steel, Phillips round-head, machine screws with plated-steel toggle nuts.
2522-30	Consists of (3) 1/4–20 x 2" type-304 stainless steel, Phillips round-head, machine screws with metal expansion shields.

2. **Grab Bar Fastener** — Bobrick has a grab bar fastening system that secures all Bobrick grab bar series; **one Bobrick fastener is required for each flange.** Install grab bar without backing in wall requires minimum 5/8" (16mm) thick painted or tiled drywall.

WingIt™ Fastener No.	Description
251-4	Consists of (3) 10–32 x 5/16" round-head, Phillips 18/8 stainless steel screws. (1) WingIt grab bar fastener.

3. **Optional Anchor Device** — Bobrick grab bar anchor device includes stainless steel machine screws to be used for attaching grab bars to anchors; **one Bobrick concealed anchor device is required for each flange.**

Optional Anchor No.	Description
2583	Anchor for 3/4" to 1" (19-25mm) panel 1 anchor required for each flange.
2586	Anchor for 1/2" to 1" (13mm) panel 1 anchor required for each flange.

SPECIFICATION:

Grab bar shall be type-304 stainless steel with satin finish. Grab bar shall have 18-gauge (1.2mm) wall thickness and 1-1/2" (38mm) outside diameter. Concealed mounting flanges shall be 1/8" (3mm) thick stainless steel plate, 2" x 3-1/8" (50 x 80mm), and equipped with two screw holes for attachment to wall and to floor. Flange covers shall be 22 gauge (0.8mm), 3-1/4" (85mm) diameter x 1/2" (13mm) deep, and shall snap over mounting flange to conceal mounting screws. Ends of grab bar shall pass through concealed mounting flanges and be heliarc welded to form one structural unit. Grab bar shall comply with barrier-free accessibility guidelines (including ADAAG in the U.S.A.) for structural strength.

Grab Bar shall be Model 819298 of Bobrick Washroom Equipment, Inc., Clifton Park, New York; Jackson, Tennessee; Los Angeles, California; Bobrick Washroom Equipment Company, Scarborough, Ontario; Bobrick Washroom Equipment Pty. Ltd., Australia; and Bobrick Washroom Equipment Limited, United Kingdom.