



AMERICAN SPECIALTIES, INC.
 441 Saw Mill River Road, NY 10701
 (914) 476.9000 • (914) 476.0688
 www.americanspecialties.com

MODEL №: 8209

ISSUED: 07/11

REVISED: 3 April 2013

RECTANGULAR PHENOLIC FOUR-LEG FOLD-UP SHOWER BENCH

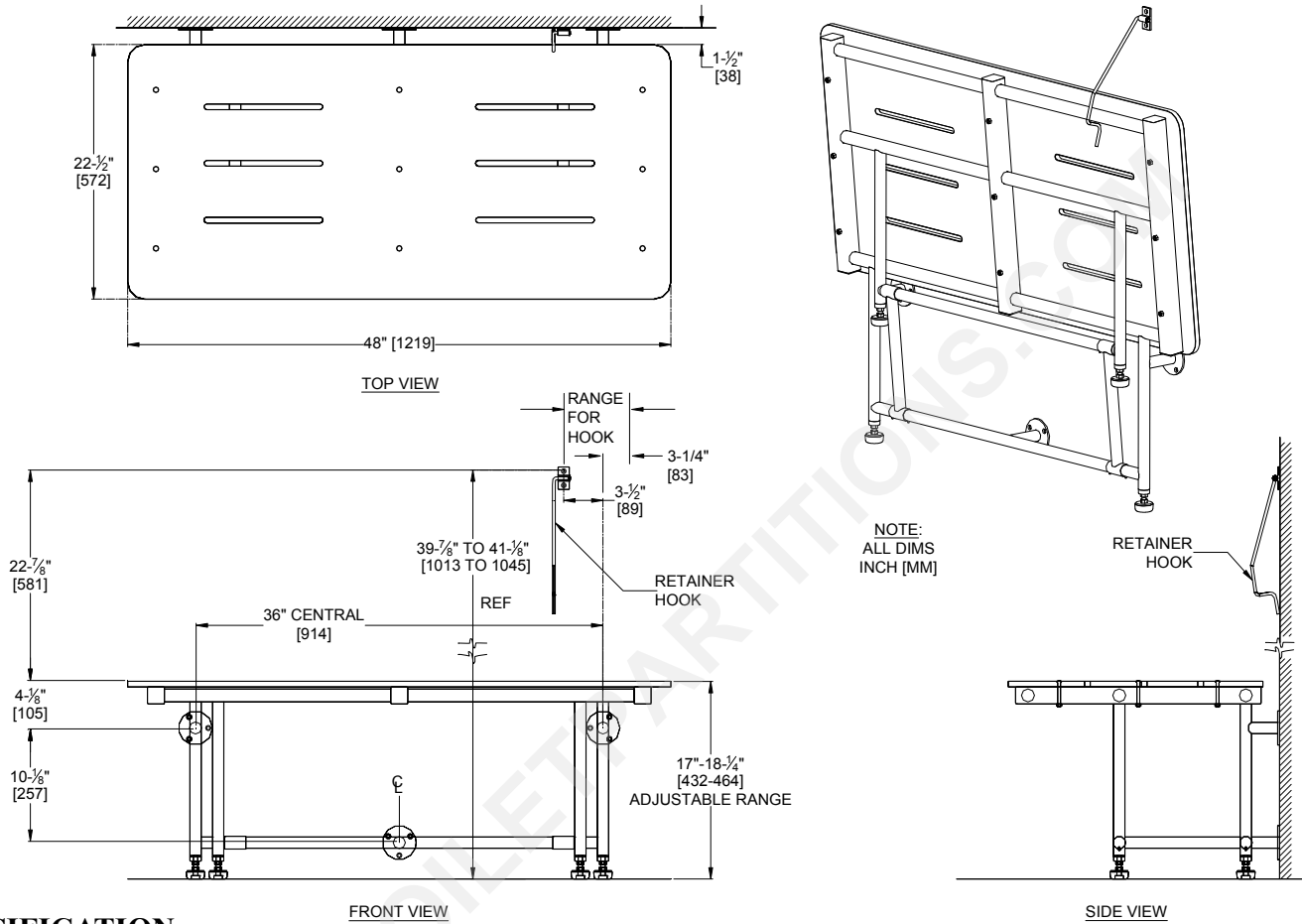

SPECIFICATION

Rectangular Phenolic Four-Leg Fold-up Shower Bench shall have all metal parts fabricated of type 304 stainless steel 18-8 alloy. Seat frame shall be 1-1/2" (38) square x 18 gauge with black plastic end caps and support legs shall be 1-1/8" diameter (Ø29) x 16 gauge and 1" diameter (Ø 25) x 14 gauge and pivoting sleeves shall be 1-1/8" diameter (Ø29) x 20 gauge with 3/16" (4.8) thick mounting flanges. All exposed surfaces shall have satin finish. Structural assembly shall be of welded construction and all exposed edges and corners shall be radiused and/or deburred. Seat shall be solid phenolic with white top and bottom surfaces and shall have black edges. Legs shall fold up when in retracted position to provide low profile against wall. Hook (provided) shall retain seat in storage position. Rubber cushioned stainless steel leveling feet shall lock-adjust throughout installation height range and compensate for uneven floors. Unit shall satisfy 2010 ADA Accessibility Standards when mounted properly.

Rectangular Phenolic Four-Leg Fold-up Shower Bench shall be Model № 8209 of American Specialties, Inc., 441 Saw Mill River Road, Yonkers, New York 10701- 4913

INSTALLATION

This unit is surface mounted. Installer/construction contractor must provide concealed anchor plate or blocking as specified in construction documents or as required by local building codes prior to wall finishing. Fasten unit flanges to concealed anchor or blocking plate with appropriate hardware (by others). See "STRENGTH" section below. Note that concealed mounting plates or anchors and hardware are not supplied with this product and must be specified separately. Ensure that mounting configuration complies with local building codes. Adjust leveling feet to provide even load transfer to floor and lock with nuts (provided) to maintain position.



AMERICAN SPECIALTIES, INC.
441 Saw Mill River Road, NY 10701
(914) 476.9000 • (914) 476.0688
www.americanspecialties.com

MODEL №: 8209

ISSUED: 07/11

REVISED: 3 April 2013

RECTANGULAR PHENOLIC FOUR-LEG FOLD-UP SHOWER BENCH

STRENGTH

ASI Shower Seats are designed to meet and exceed 2010 ADA Accessibility Standards and ICC/ANSI A117.1 guidelines that fabricated product shall be of adequate strength to support a load of 250 pounds (113.4 kg) and unit shall conform to size and edge clearances as diagrammed. Mounting to the wall is a critical part of the system to meet this requirement. To withstand the shear, tension or pullout, and torsion loads generated by the maximum loading, the fastener system must be adequately sized. Unit is load rated to support a weight of 1000 lbs (454 kg) when properly installed and has been tested to successfully hold a weight in excess of 1,250 lbs (567 kg).

MATERIALS

Tubes: 14 gauge (.075" <1.9> thick) 1" diameter (Ø25) and 16 gauge (.06" <1.5> thick) & 20 gauge (.04" <1.0> thick) 1-1/8" diameter (Ø29), 1-1/2" (38) square x 18 gauge, all type 304 stainless steel. Unitized welded construction. Exposed surfaces have satin finish. Edges and corners are radiused and burr free.

Flanges: 3/16" (4.8), type 304 stainless steel. Exposed surfaces have satin finish. Edges are radiused and burr free.

Brackets: 12 gauge (.106" <2.7> thick), type 304 stainless steel. Exposed surfaces have satin finish. Edges are radiused and burr free.

Seat: Solid Phenolic 1/2" x 22-1/2" x 48" (13 x 572 x 1219) nonporous seat has white top and bottom surfaces with semi-gloss finish and black edges with radiused and burr free corners. Seat shall have slots for water drainage and user slip resistance. Support frame has black plastic end caps. Mounting hardware is smooth stainless steel FH plow bolts with castle nuts on bottom.

OPERATION

Fold-up Shower Seat requires only one hand operation to manually lower to horizontal position for use or raise for departure and arrival. Rear load feet remain on floor with rear frame mounted to wall and never need adjustment after correct installation. Front legs fold up automatically when seat is raised. Hook prevents seat from dropping. Rubber cushions on load leveling feet prevent shocks to floor surface during deployment and use. Unit may be hosed for cleaning at same time as shower enclosure.