

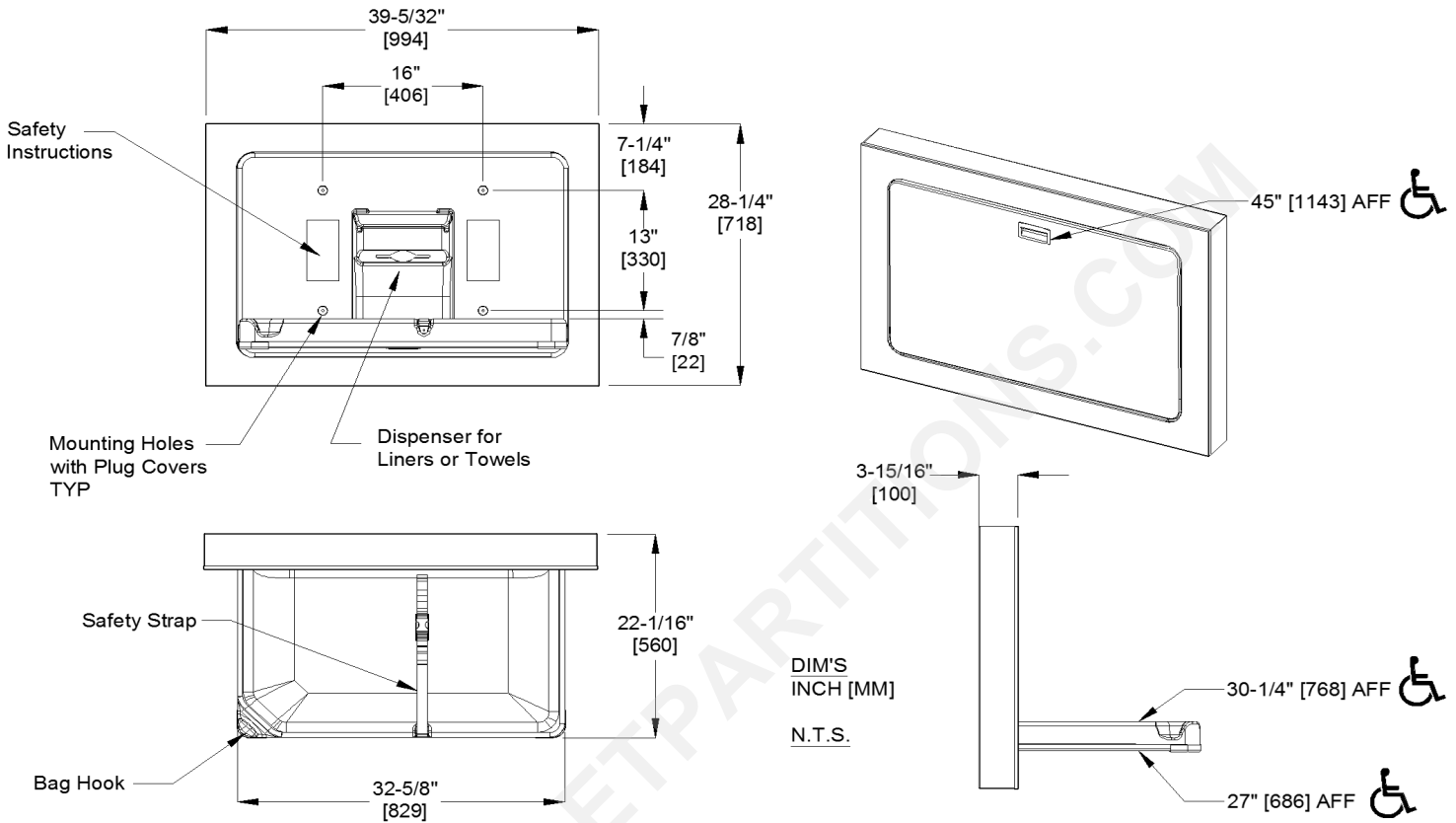

**AMERICAN SPECIALTIES, INC.**  
 441 Saw Mill River Road, Yonkers, NY 10701  
 (914) 476.9000 • (914) 476.0688  
 www.americanspecialties.com

<b>MODEL №:</b>	<b>9018-9</b>
<b>ISSUED:</b>	08/13
<b>REVISED:</b>	2 Dec 2015

**SURFACE MOUNTED STAINLESS STEEL HORIZONTAL BABY CHANGING STATION (PG 1 of 2)**



**SPECIFICATION**

Surface Mounted Stainless Steel Baby Changing Station shall be horizontal format and shall protrude no more than 4" [102] from wall when in retracted position. Unit shall comply with 2010 ADA Accessibility Standards, ASTM F2285-04, and EN 12221-1. Unit shall support a static load of 300 lbs. [136.1 kg] and be tested in excess of 350 lbs. [158.8 kg]. Unit shall be fabricated of non-porous plastic (FDA approved HDPE) tested according to ASTM G21 and ASTM G22. Unit shall contain a door facing and wall flange dress trim of satin finished 18 gauge type 304 stainless steel. Unit shall contain a surface mounting collar made from satin finished 22 gauge type 304 stainless steel. No parts of the operating mechanism shall be accessible when unit is open or closed to provide a tamper-resistant and pinch proof user environment. Unit shall have a damped gas spring to assist user in opening and closing bed tray with the use of one hand. Unit shall be provided with one integral heavy-duty bag hook. Unit shall provide a bed-liner dispenser that may be easily converted to a multi-fold towel dispenser with no adapters. Unit shall provide graphics and instructions in four languages on interior back. Unit shall be provided with an adjustable two-part vinyl coated child protection safety-strap mounted with concealed fasteners on high walls of cradle. Entire unit shall be assembled of completely sealed components to provide easy cleaning and no penetration zones to harbor microbes or bacteria. Unit shall mount on standard stud wall dimensions and with proper anchoring may mount on all suitable wall constructions. Mounting fasteners shall be concealed after installation using color matched recess plug-covers supplied. Unit bed tray and back shall be light grey in color and entire unit shall be recyclable at end of usable life. Unit shall be warranted for five (5) years against defects in material or workmanship.

Surface Mounted Stainless Steel Horizontal Baby Changing Station shall be Model № 9018-9 as manufactured by American Specialties, Inc., 441 Saw Mill River Road, Yonkers, NY 10701-4913



**AMERICAN SPECIALTIES, INC.**  
441 Saw Mill River Road, Yonkers, NY 10701  
(914) 476.9000 • (914) 476.0688  
www.americanspecialties.com

**MODEL №: 9018-9**

**ISSUED: 08/13**

**REVISED: 2 Dec 2015**

## **SURFACE MOUNTED STAINLESS STEEL HORIZONTAL BABY CHANGING STATION (PG 2 of 2)**

### **INSTALLATION**

Installation instructions along with operation and maintenance manual are provided with each unit. Unit is surface mounted using hardware supplied through concealed mounting holes. Hardware kit supplied has fasteners suitable for metal or wood stud walls in dry locations and general hollow wall construction where adequate substrate strength is obtained. Fasteners and anchors for masonry walls are not provided. Wall reinforcement must be suitable to sustain transfer of maximum unit loading. Mounting hole plug covers are supplied to conceal fasteners after installation.

For compliance with 2010 ADA Accessibility Standards, install unit so that top edge of changing table is 30-1/4" above finished floor (AFF). See installation instructions packed with unit.

1. Locate wall studs at 16" [406] OC for fastening the station. If two (2) wall studs cannot be used, use two (2) screws into ONE stud and drill pilot holes and install toggle fasteners securely in the wall at non-stud location.
2. Attach unit to wall studs with four (4) 1/4" x 3" long Phillips pan head self-tapping screws through flat washers.
3. Where wall studs are not available attach with four (4) 1/4" - 20 x 3" pan head bolts with flat washers into toggles or expansion nuts.

### **OPERATION**

Unit platform is shaped to keep a child restrained from rolling out of the bed. Unit is easily opened and closed by user with one hand in any location and handle cavity is provided on door face for preferred use. Unit is operable with less than 5lb of force (22.2N) while not requiring any tight grasping, pinching or twisting of the wrist. Bed liner/towel dispenser presents liners or towels for user hygiene and convenience. Dispenser lid is provided for sanitary protection and ease of loading of wipes or liners. Safety strap is easily adjustable by user for baby size and Sure-Lock latch securely resists opening until released by opposing finger pressure by adult caretaker/parent. Liners/towels are easily replenished by service personnel as required.