



**AMERICAN SPECIALTIES, INC.**

441 Saw Mill River Road, Yonkers, NY 10701 (914) 476-9000  
www.americanspecialties.com

MODEL No: 0401

ISSUED: 01-87

REVISED: 12-06

**HEAVY DUTY STAINLESS STEEL SOAP DISH**

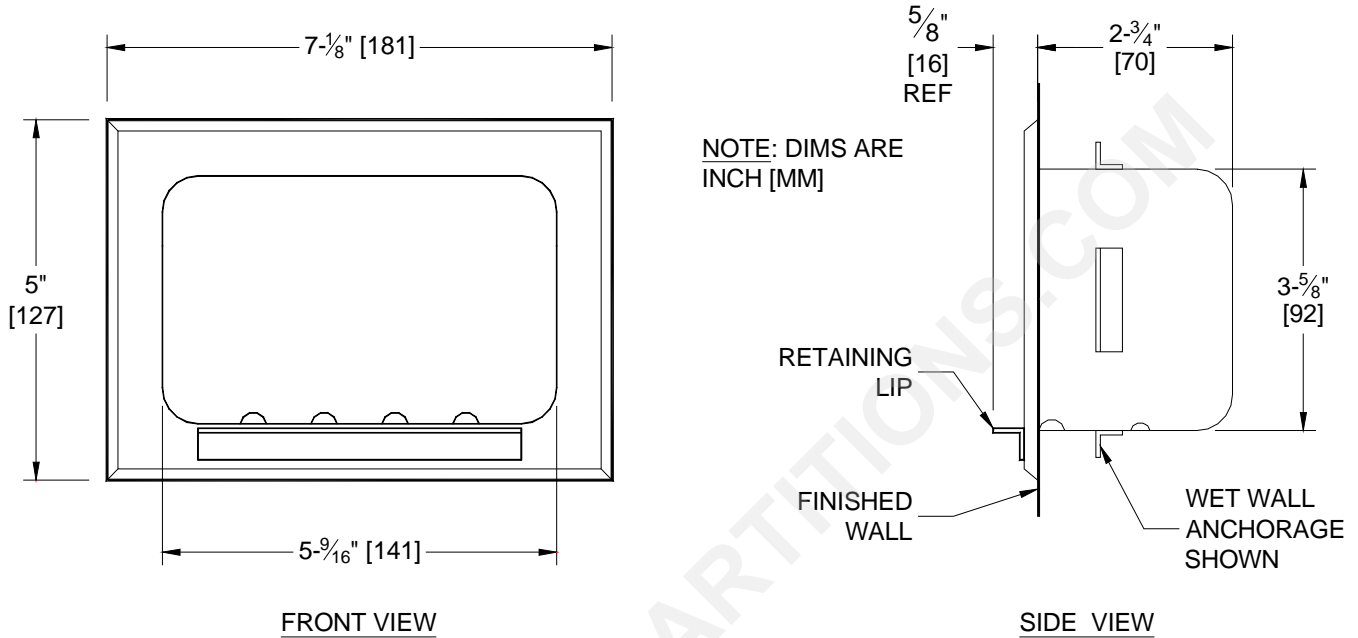

**SPECIFICATION**

Heavy Duty Stainless Steel Soap Dish for wet wall mounting shall be formed of 20 gauge alloy 18-8 seamless deep drawn stainless steel, type 304. Exterior shall have polished bright finish. Retaining lip with rounded corners shall be welded to body and shall project 5/8" (16) from bezel. Anchors shall be 22 gauge stainless steel and shall be welded onto unit. Water runoff path shall be provided as pattern of raised dimples on soap shelf and shall prevent soap from slipping.

**Heavy Duty Stainless Steel Soap Dish shall be Model N° 0401 of American Specialties, Inc., 441 Saw Mill River Road, Yonkers, New York 10701-4913**

**INSTALLATION**

Fill rough wall opening with tile cement. Apply cement to back shell and anchors and immediately insert into wall opening to displace excess cement from RWO to set flange flush with face of finished wall. Clean off excess cement around unit immediately. Allow unit to set and cement to cure before use.

**Rough Wall Opening (RWO) required is .....6-1/8" W x 4-1/8" H x 3" D (156 x 105 x 76)**

**OPERATION**

Raised dimples on the soap shelf allow water to drain away and provide gripping surface to retain soap.