

Electrical Specifications: 110-120 AC, 8 Amp, 60 Hz, 1000 Watts, Single Phase, cULus Listed.



***RECOMMENDED MOUNTING HEIGHTS**

Children's Washrooms, ages 3-4	36" (915mm)
Children's Washrooms, ages 5-8	40" (1015mm)
Children's Washrooms, ages 9-12	44" (1120mm)
 Universal Design	48" (1219mm)

*Bottom screw hole of mounting base to finish face of floor

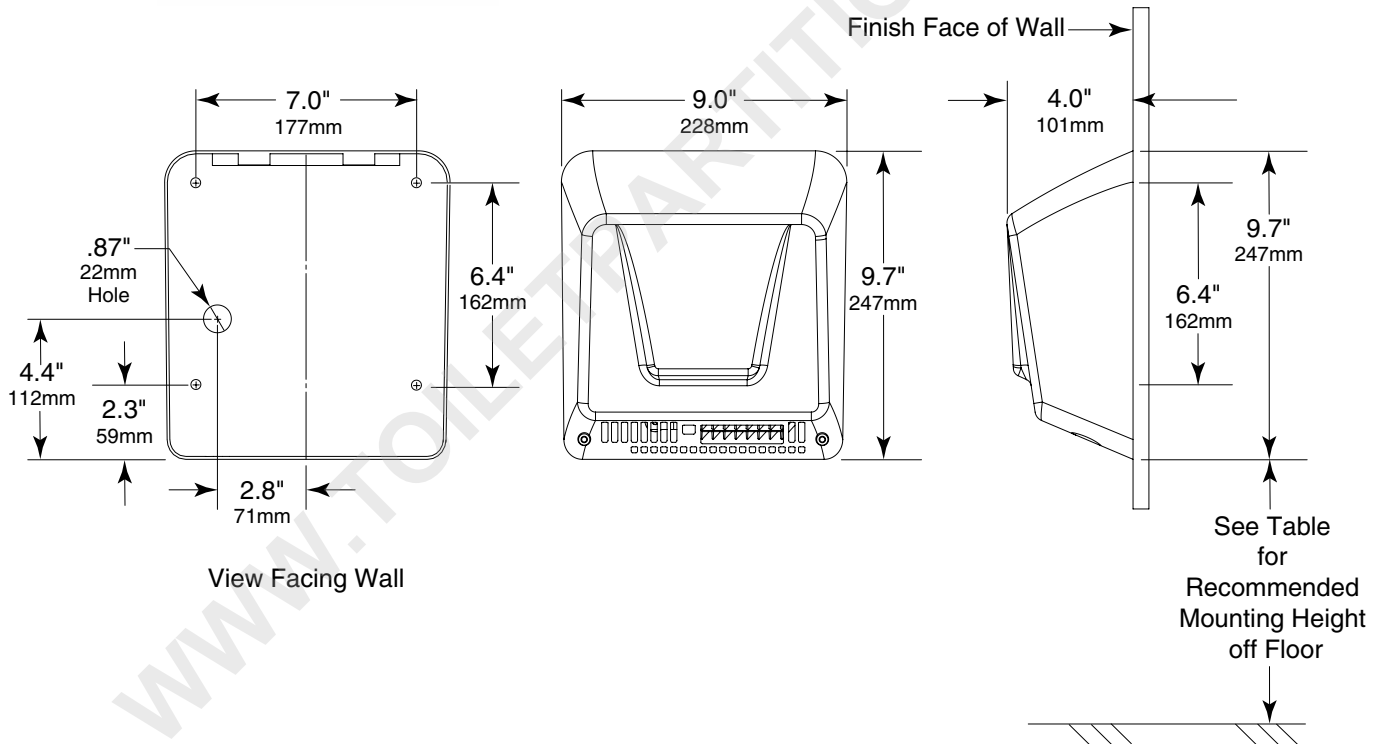

MATERIALS:

Cover — One-piece, aluminum die-casting with white epoxy enamel finish. Cover projects no more than 4" (100mm) from wall and is secured to mounting base.

Mounting Base — Equipped with four mounting holes and one 7/8" diameter hole suitable for between-wall wiring. Equipped with 4 mounting bolts.

Motor/Fan — Thermally-protected brush type universal motor (100- 240V) with 7500 rpm with a single shaft. Dryer shall deliver 88 cubic feet per minute of air volume at velocity of 6800 fpm.

Heating Element — Coiled Nickel-chrome heating element, protected by integral automatic thermal overload device. Located on fan outlet, to heat air without hot spots and remain inaccessible to vandals. Dryer provides a 70° F temperature rise.

continued . . .

Electronic Control — Infrared sensor automatically turns dryer on when hands are held under air-outlet opening and across path of sensor. Remove hands from path of sensor and dryer stops. Electronic sensor has automatic shutoff approximately 30 seconds after dryer turns on if an inanimate object is placed across air-outlet opening. After inanimate object is removed, electronic sensor automatically resets itself and dryer operates normally.

OPERATION:

No-Touch Operation: Electronic sensor automatically turns dryer on when hands are held under air outlet opening and across path of sensor. Remove hands from path of sensor and dryer stops. Dryer operates only when actually drying hands which saves energy and operating costs. Electronic sensor will automatically shut dryer off 30 seconds after dryer turns on if an inanimate object, such as tape or chewing gum, is placed across air-outlet opening. After inanimate object is removed, electronic sensor automatically resets itself and dryer operates normally.

2-Year Limited Warranty — Gamco extends a limited 2 year warranty from the date of purchase for DR-510 hand dryer on all parts, except motor brushes, to the original owner of the installed unit against defects in factory workmanship or material under normal use and service. This warranty is limited to the repair or exchange of defective parts at the option of Gamco.

SPECIFICATION:

Gamco warm air hand dryer is a surface-mounted ADA (American Disabilities Act) compliant dryer powered by a universal brush motor. Motor shall be thermally protected brush type with minimum 7500 rpm with a single shaft. Dryer shall deliver 88 cubic feet per minute of air volume (6800 lfm). This small, low profile, ADA compliant hand dryer is multi-voltage running on 110 up to 240 Volt AC electrical supply. Operation is automatically controlled on/off, by an infrared sensor. Unit shall be cULus Listed. Unit shall be protected by a 2 year limited warranty on all parts except motor brushes.

Surface-Mounted Hand Dryer shall be Model DR-510 of Gamco Commercial Restroom Accessories, One Gamco Place, Durant, OK, 74701-1910

WWW.TOILETPARTS.COM