

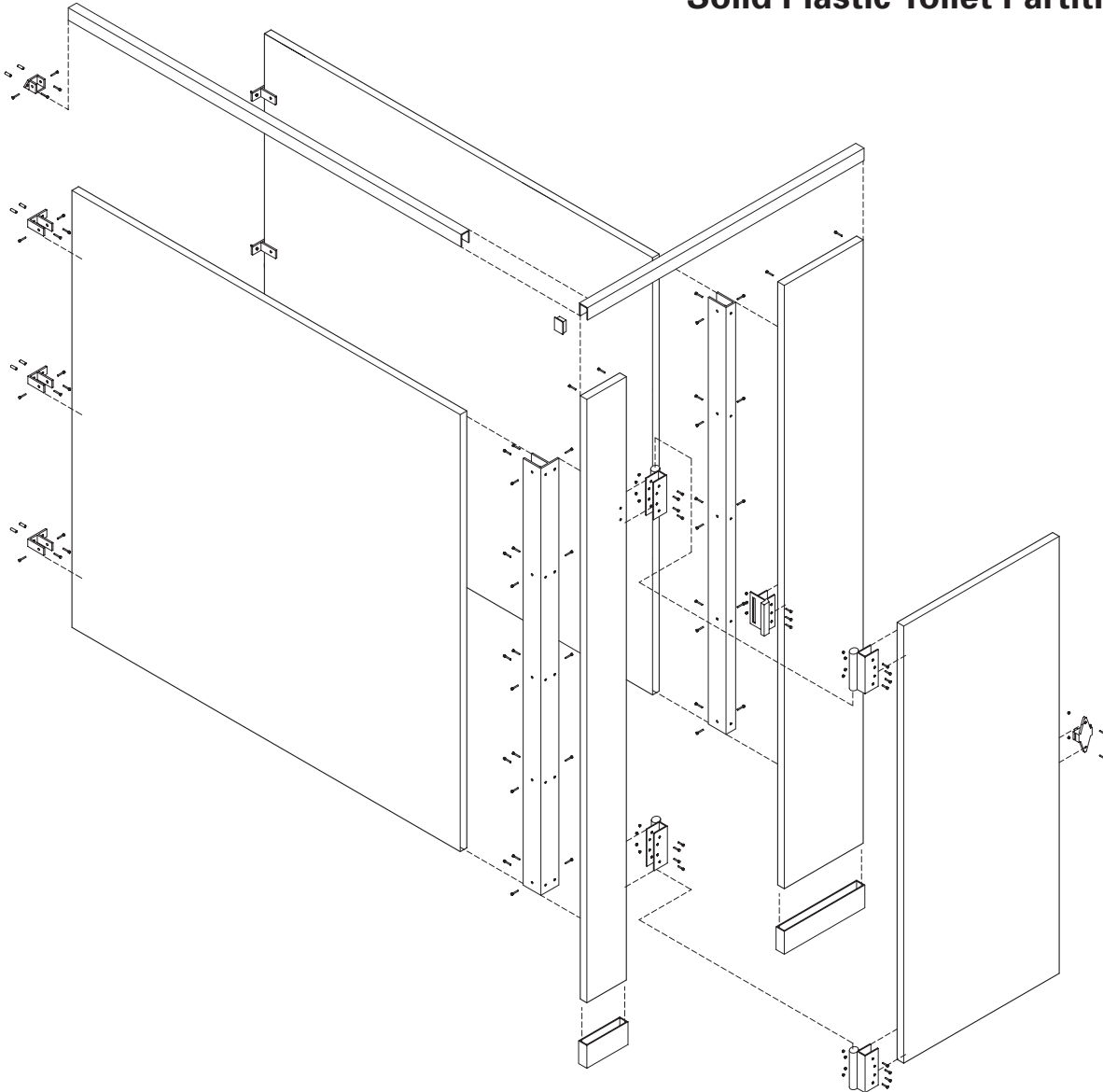

Installation Manual

Solid Plastic Toilet Partitions





Installation Manual for Solid Plastic Toilet Partitions

Table of Contents

General Notes and Tools Required	3
Fasteners	4
STEP 1: Establish Anchor Shoe Locations	5
STEP 2: Secure Anchor Shoes to Floor	6
STEP 3: Erect Panels	7
STEP 4: Prepare Brackets for Wall Pilaster	8
STEP 5: Erect Wall Pilaster	9
STEP 6: Prepare Pilaster for Door	10
STEP 7: Fasten "U" Channel to Pilaster	11
STEP 8: Erect Pilaster	12
STEP 9: Prepare Door for Hanging	13
STEP 10: Hang Door	14
STEP 11: Erect Remaining Pilasters	15
STEP 12: Secure Headrail Brackets	16
STEP 13: Place Headrail	17
Appendix A: Pilaster Leveling	18
Appendix B: Pilaster Reinforcing Channel	19
Appendix C: Barrel Hinges	20 - 22
Appendix D: Latch and Keeper	23
Appendix E: Continuous Hinges	24
Appendix F: Integral Hinges	25 - 26
Appendix G: Alcove Pilasters	27
Appendix H: Ceiling Hung	28
Appendix I: Floor to Ceiling	29



Installation Manual for Solid Plastic Toilet Partitions

General Notes

The following installation instructions are based on headrail braced compartments in the most common unit arrangement. Other arrangements will be encountered, i.e. units contained between two walls or between two free-standing panels. For details on ceiling hung and floor to ceiling connections, refer to the appendix. Always adhere to applicable building codes.

Ceiling hung and floor to ceiling toilet partitions require an overhead structural member (normally a channel). This member is supplied, installed and drilled by others. Stud assemblies are available from Hadrian, but Hadrian does not install them. Stud assemblies should be in place prior to application of finished ceiling.

Hadrian recommends the use of a Pilaster Reinforcing Channel for self-supporting pilasters that are 16" (406mm) wide or wider.

FINAL LAYOUT DRAWINGS

For dimensional information, refer to your plan layout and dimensional details. Note in particular the relationship of the panels to the pilasters (panels do not necessarily fall on the center line of the pilaster).

HEAT SINK STRIPS

If ordered, heat sink strips come pre-installed to the underside of applicable doors and panels.

STORAGE

Solid Plastic is an exceptionally durable product, designed to stand the test of time. For optimum performance and to prevent possible warping of material, it is critical that the following guidelines be adhered to:

- 1) Plastic material must remain flat until the time of installation.
- 2) Plastic material must remain at approximately 68° F for a period of 24 hours before and after installation.

It is the distributor's responsibility to supply end-users with maintenance and warranty information.

Recommended Safety Equipment

Safety Glasses



Safety Gloves



Safety Shoes



Hard Hat



Tools Required

- 4 ft. level
- Chalk line
- Tape Measure
- Hammer
- Hammer drill
- 5/16" (8mm) masonry bit
- Miscellaneous drill bits
- Miscellaneous screw driver bits
- Adjustable wrench
- Hacksaw
- 14" (356mm) shim block to rest panels on for easier installation
- 6-lobe security driver bits



Fasteners

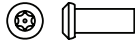

Barrel Nut
620123

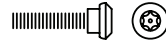

1" Barrel Screw
620124



1.75" Pan Head Screw
620052



5/8" Pan Head Screw
620051



Plastic Anchor
620053

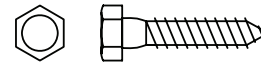

#20 x 1.75" Lag Bolt
620126



#10 x 0.75" Flat Head Screw
620125

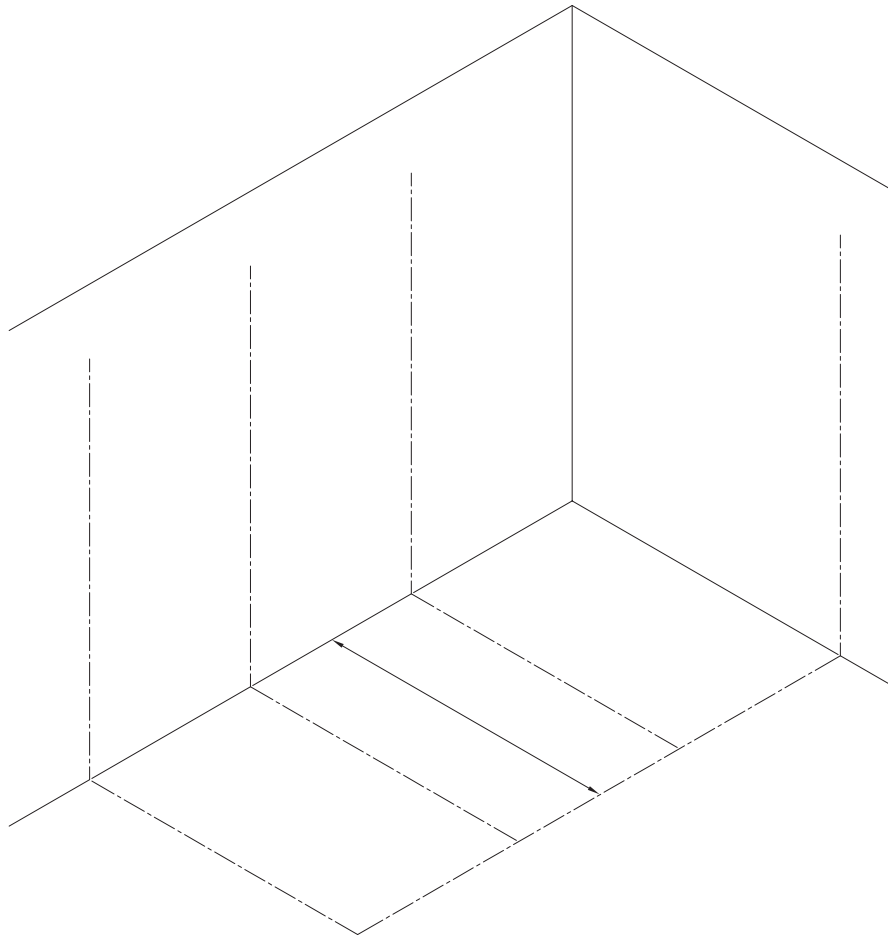

STEP 1: Establish Anchor Shoe Locations

Establish the front centerline by taking the overall compartment dimension and deducting 0.5" (13mm).

Use final layout drawing to determine the location of the first pilaster along the centerline.

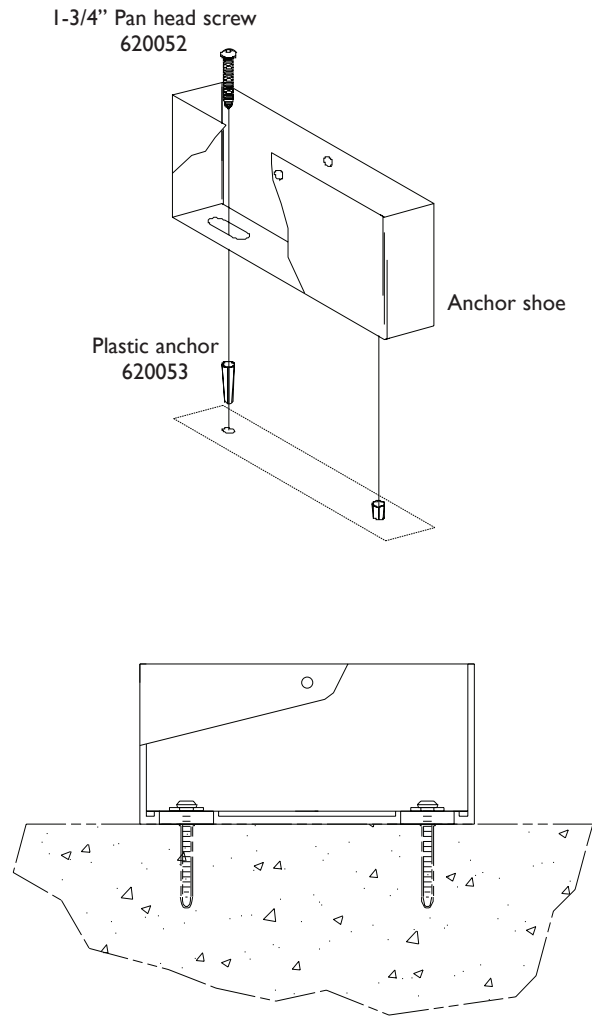

STEP 2: Secure Anchor Shoes to Floor

Set the pilaster anchor shoe in place along the centerline and mark the shoe hole locations.

Remove shoe. Drill holes at marks and insert plastic anchors. Replace shoe and secure to floor with 1.75" pan head 6-lobe security screw. Continue to secure remaining shoes in place as outlined in the final layout drawings.

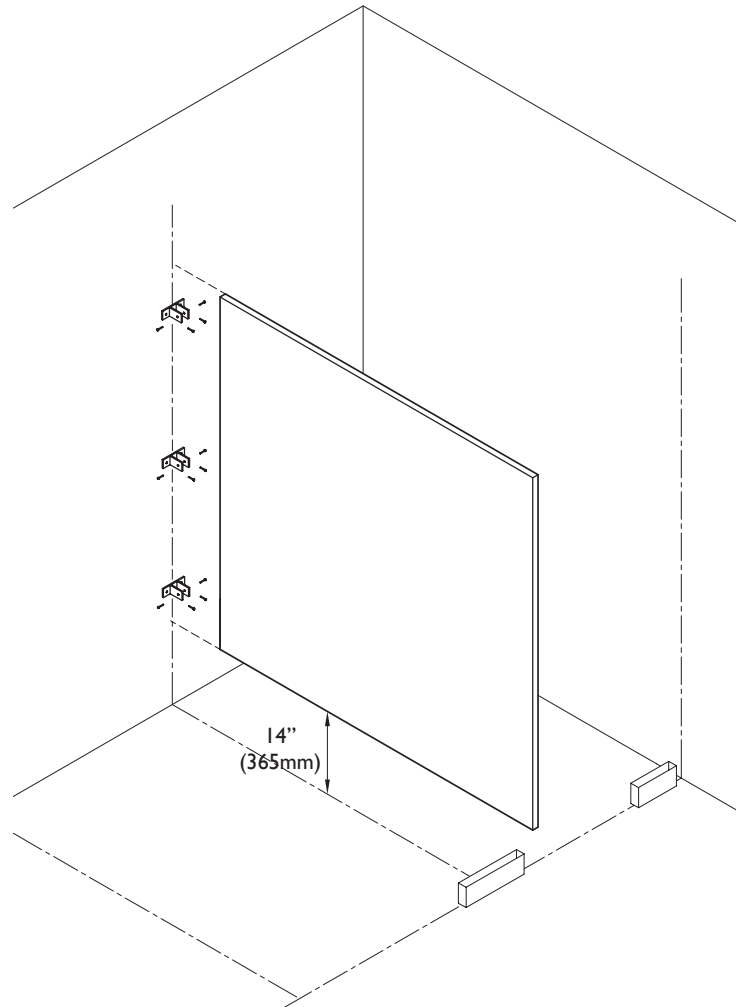

STEP 3: Erect Panels

Using your centerline locations, fasten 3 panel brackets to the back wall using 1.75" pan head screws (620052) and plastic anchors (620053). Brackets should be 20" (508mm), 41.5" (1054mm) and 63" (1600mm) from the floor.

Fasten panel to panel brackets using 5/8" pan head screws (620051). The dimension from the floor to the underside of the panel should be 14" (356mm). For ease of installation, rest panel on 14" (356mm) shim block while fastening to brackets.

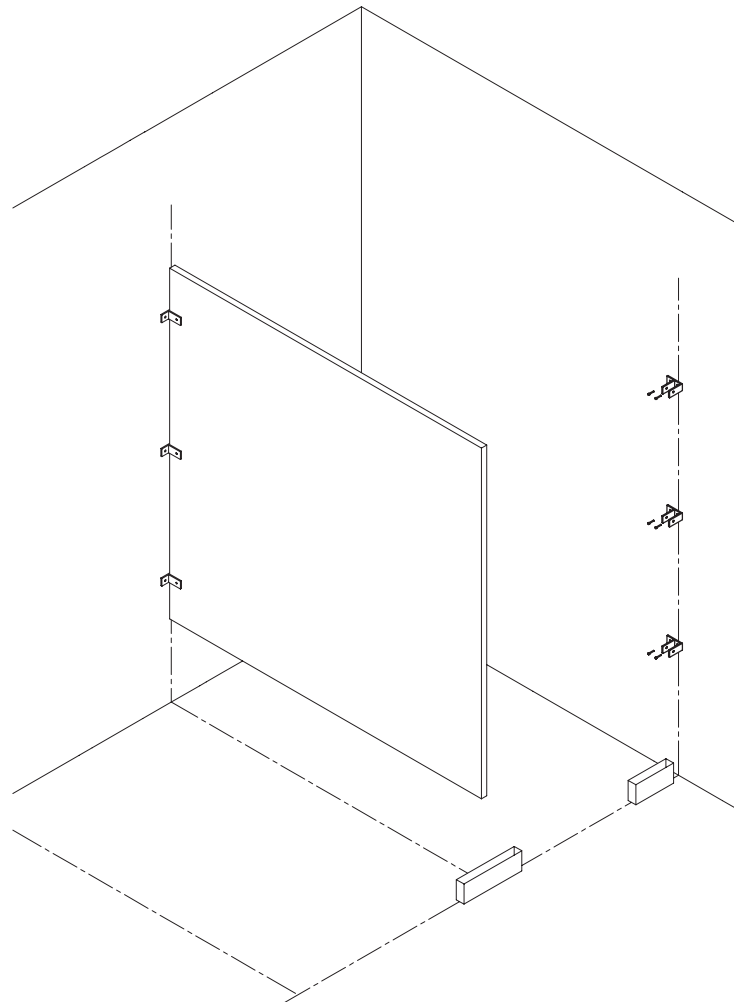

STEP 4: Prepare Brackets for Wall Pilaster

Fasten 3 single ear ("F") brackets to side wall at centerline using 1.75" pan head screws (620052) and plastic anchors (620053).

Brackets should be 20" (508mm), 41.5" (1054mm) and 63" (1600mm) from the floor.

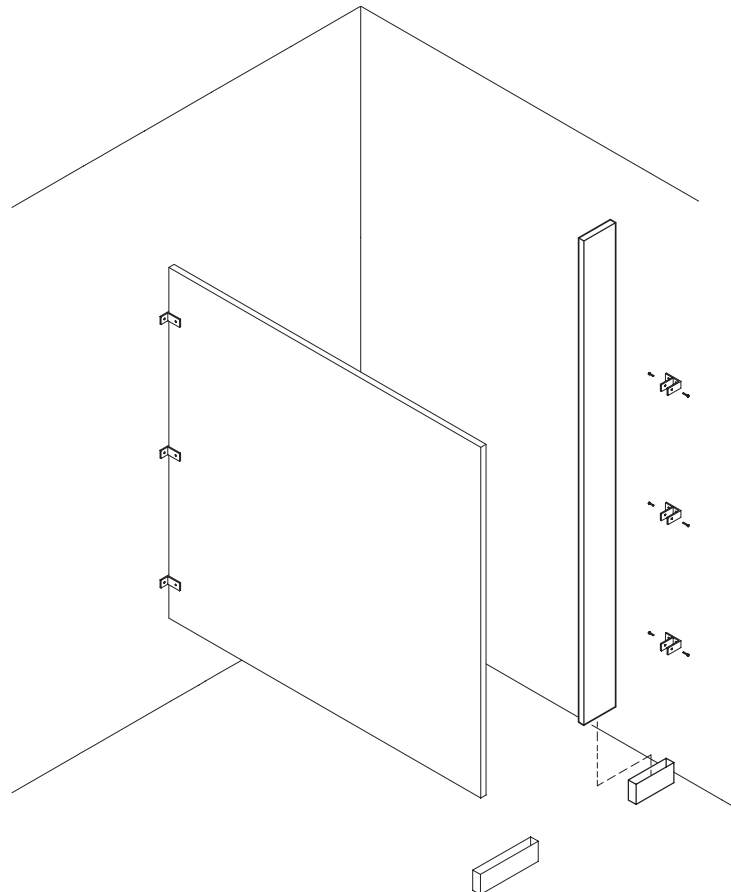

STEP 5: Erect Wall Pilaster

Set pilaster into the anchor shoe and wall brackets. If necessary, use leveling bolt underneath the pilaster to level (refer to appendix A). Fasten the pilaster to the wall brackets using 5/8" pan head screws (620051).

*** For ceiling hung installations, refer to appendix H.

*** For floor to ceiling installations, refer to appendix I.

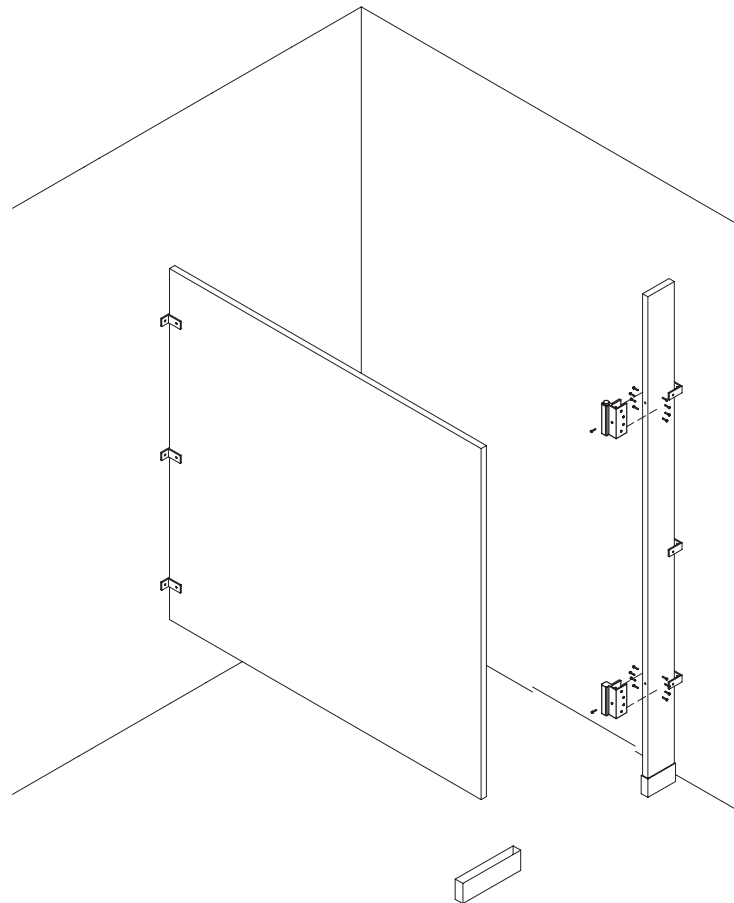

STEP 6: Prepare Pilaster for Door

Drill a 1/16" (2mm) diameter pilot hole, 0.25" deep, into the edge of the pilaster 21.75" (552mm) from the floor. Drill another pilot hole into edge of pilaster 40.25" (1022mm) up from the first hole. Fasten upper and lower hinges to pilaster by securing #10 x 0.75" flat head screws (620125) through pilot holes.

Using the hinge as a template, drill holes in pilaster for through bolts.

Secure hinges to pilaster using 1" barrel screws (620124) and barrel nuts (620123).

*** For more details on barrel hinges, refer to appendix C.

*** For continuous hinges, refer to appendix E.

*** For integral hinges, refer to appendix F.

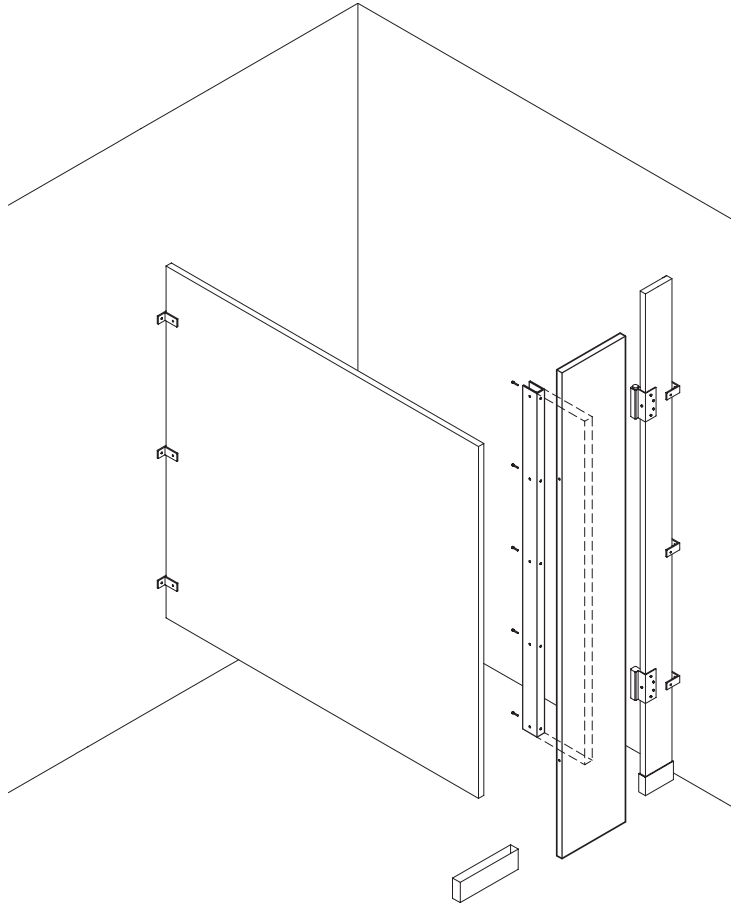

STEP 7: Fasten "U" Channel to Pilaster

Mark the next pilaster with a vertical line (off-set will be indicated on layout drawing).

Mark the top height of the panel on this line. The vertical line will serve as a guide for the "U" channel.

Pre-drill pilaster to accept screws at least 5/8" (16mm) deep.

Fasten "U" channel to pilaster using 5/8" pan head screws (620051).

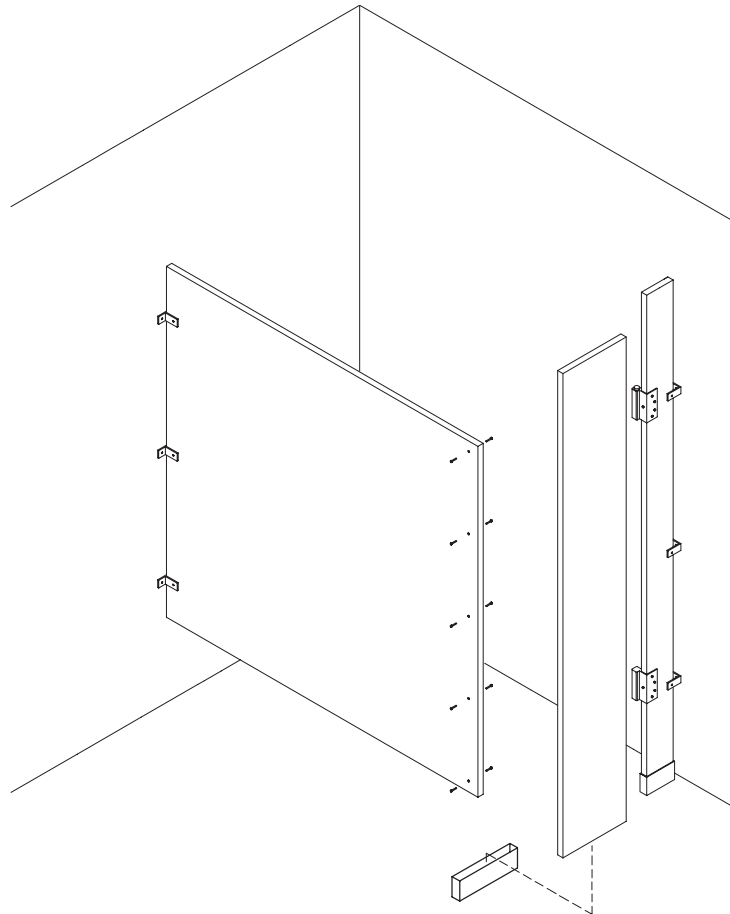

STEP 8: Erect Pilaster

Set pilaster into anchor shoe. If necessary, use leveling bolt underneath the pilaster to level (refer to appendix A). Set "U" channel into place on panel and fasten using 5/8" pan head screws (620051).

***** For ceiling hung installations, refer to appendix H.**

***** For floor to ceiling installations, refer to appendix I.**

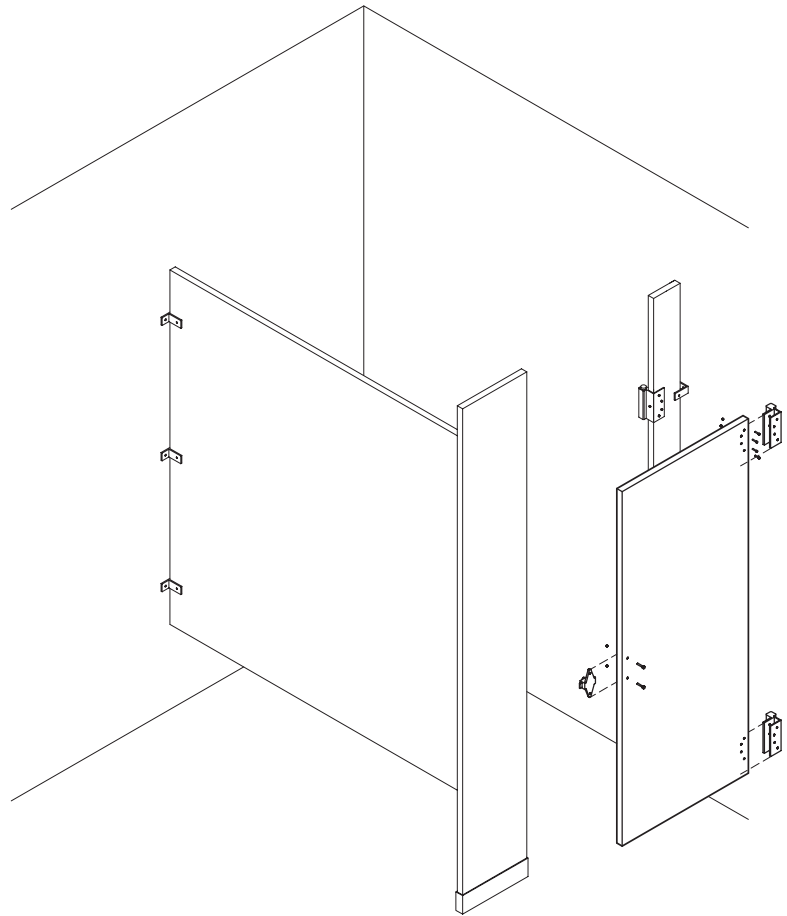

STEP 9: Prepare Door for Hanging

If using barrel hinges, drill pilot holes into hinge-side edge of door at 2.75" (70mm) from top and bottom of door. Fasten hinges to door by securing #10 x 0.75" screw (620125) through pilot holes.

Using the hinge as a template, drill holes in door for through bolts (you may need to remove the hinges to widen the holes for the through bolts).

Secure upper hinge to door using 1" barrel screws (620124) and barrel nuts (620123). **Do not through bolt the lower hinge yet.**

Through-bolt latch at midpoint of door using 1" barrel screws (620124) and barrel nuts (620123).

*** For details on barrel hinges, refer to appendix C.

*** For details on latch and keeper, refer to appendix D.

*** For continuous hinges, refer to appendix E.

*** For integral hinges, refer to appendix F.

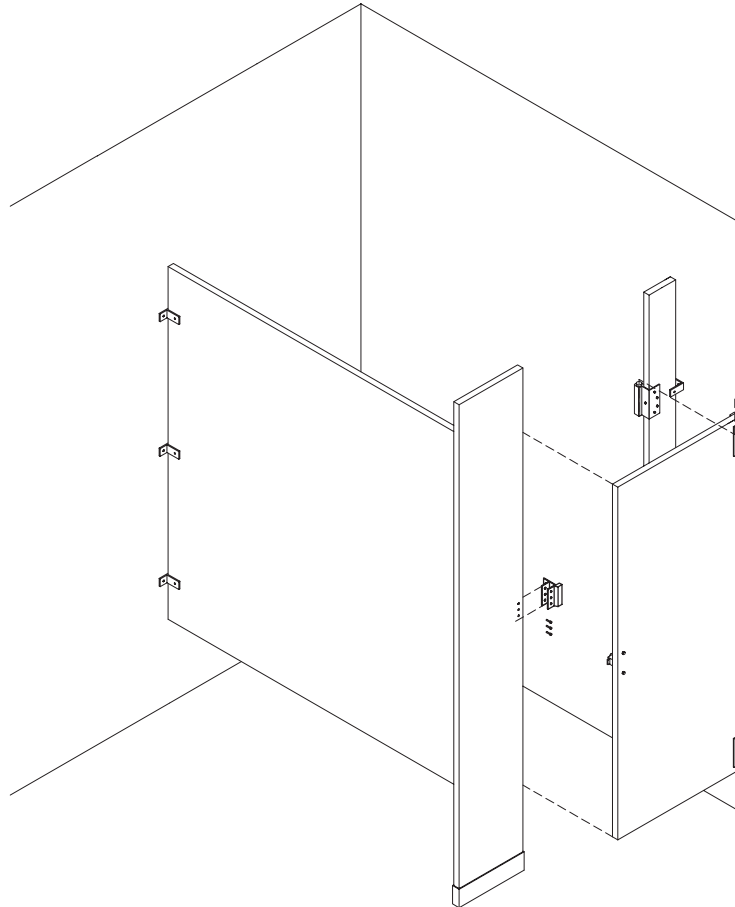

STEP 10: Hang Door

Adjust hinge cam mechanism to allow door to rest at 30 degrees open (for inswing) or closed (for outswing).

Hang door by placing upper door hinge onto hinge component already fastened to pilaster.

Slide bottom door hinge into place and fasten with through-bolts (ensure that the cardboard spacer has been removed).

***** For details on barrel hinges, refer to appendix C.**

Fasten Stop & Keeper on pilaster

***** For details on the latch and keeper, refer to appendix D.**

At this stage, you may want to pre-install headrail (without fastening) to assist in lining up and spacing pilasters (**not required for ceiling hung or floor to ceiling installations**).

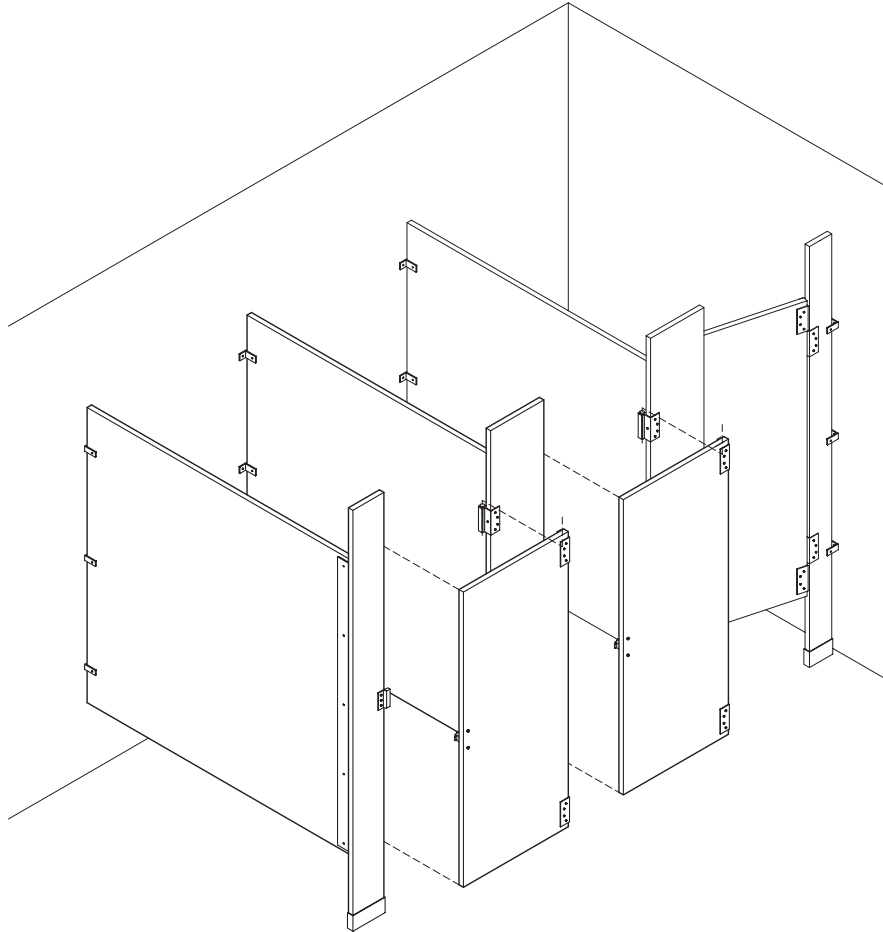

STEP 11: Erect Remaining Compartments

Ensure all pilasters are securely fastened and repeat steps 3 - 11 (as necessary) for all remaining compartments.

Hadrian recommends installing one compartment (including door) at a time.

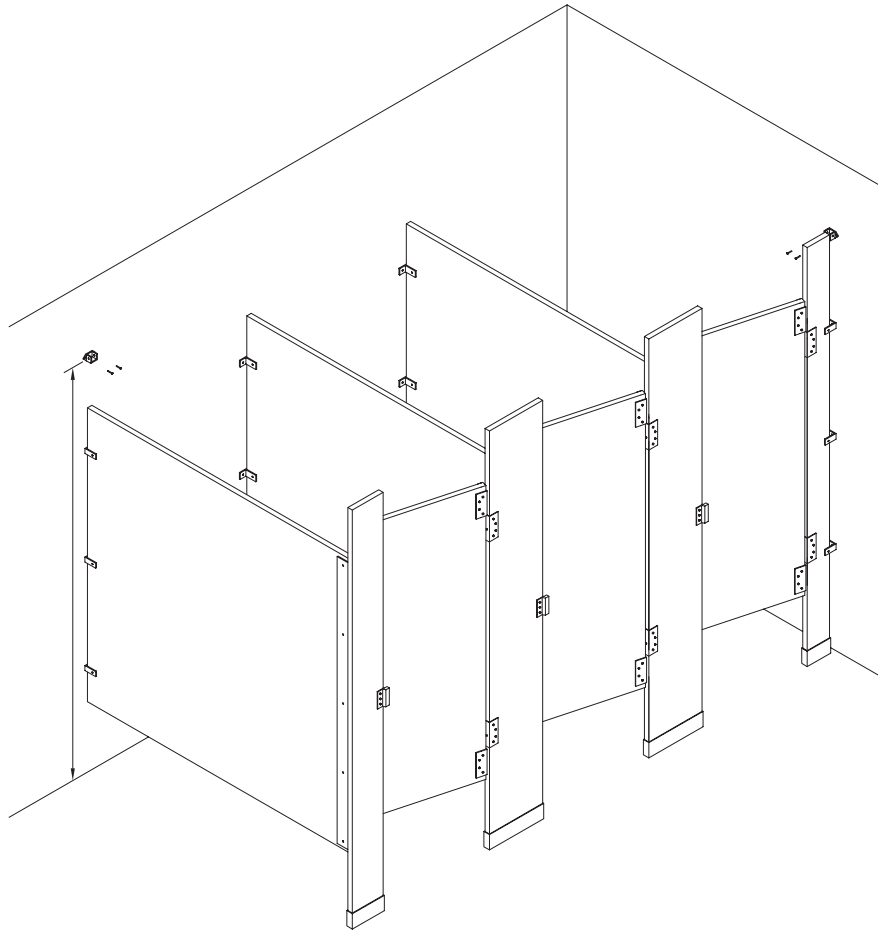

STEP 12: Secure Headrail Brackets

***** This step is not required for ceiling hung or floor to ceiling installations.**

Using 1.75" pan head screws (620052) and plastic anchors (620053), fasten headrail brackets to wall approximately 81.5" (2070mm) above the floor (some adjustment may be necessary due to varying floor conditions).

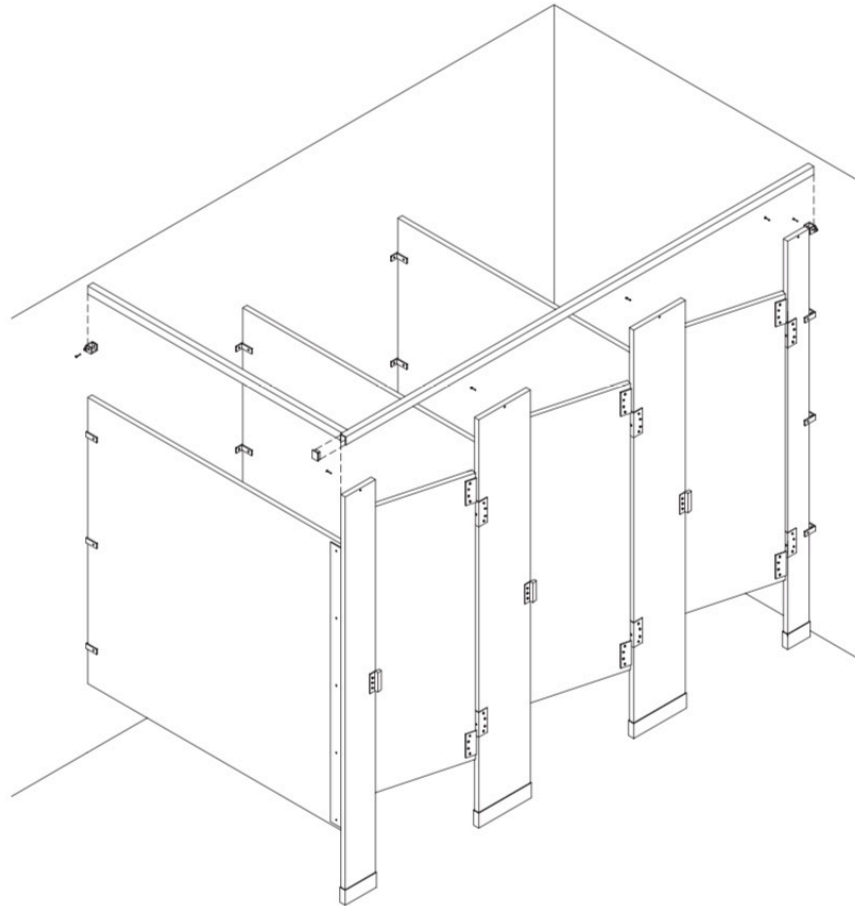

STEP 13: Place Headrail

For headrail braced installations, cap headrail over top of pilasters and slide into headrail brackets. Where 2 pieces of headrail connect in-line, join them with the snap-fit connector (always at a pilaster).

Fasten headrail to pilasters using 5/8" pan head screws (620051), ensuring that all screws are on inside of compartment. Using the same screws, fasten headrail to headrail brackets.

Secure headrail end-cap if required.

***** For ceiling hung installations headrail is not required, but a stabilizer bar MUST be installed. Refer to appendix H.**

Fasten combined coat hook and bumper.

Fasten door pull(s) for barrier-free compartments.



APPENDIX A - PILASTER LEVELING

Installation Manual for Solid Plastic Toilet Partitions

Pilaster Leveling

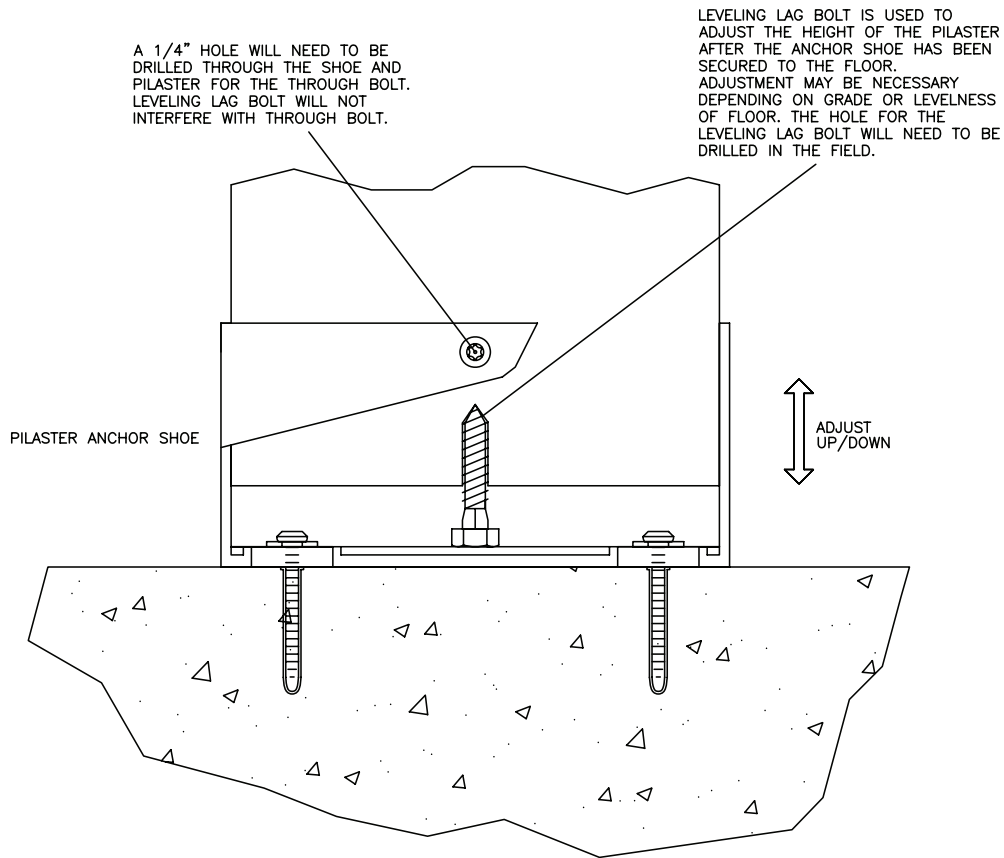



APPENDIX B - REINFORCING CHANNEL

Installation Manual for Solid Plastic Toilet Partitions

Pilaster Reinforcing Channel

Hadrian recommends the use of a reinforcing channel (part #627240) on all self-supporting solid plastic pilasters that are more than 14" (356mm) wide.

To install the reinforcing channel:

1. Position the reinforcing channel on the pilaster as indicated on layout drawings.
2. Fasten the reinforcing channel to the pilaster using 5/8" (16mm) screws through the holes supplied in the reinforcing channel.

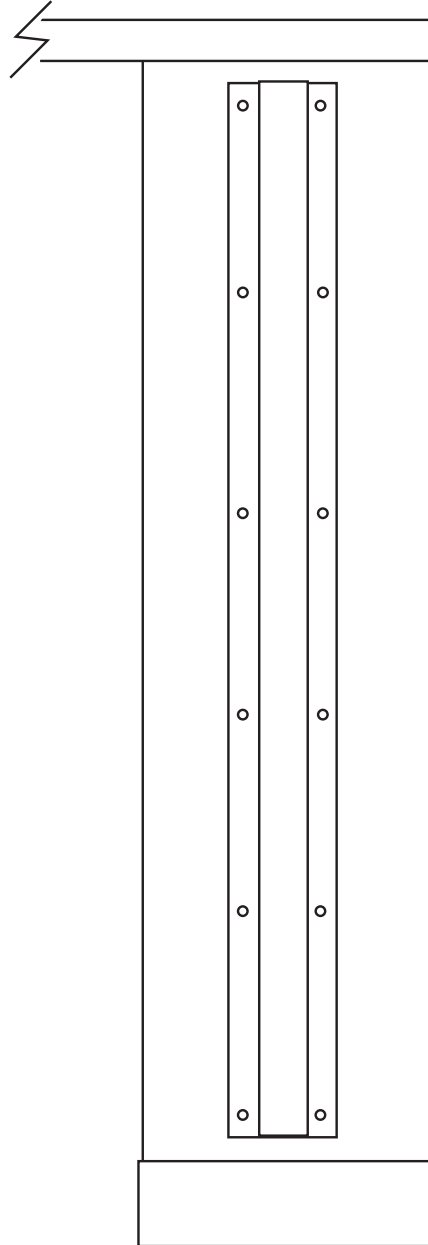



APPENDIX C - BARREL HINGES

Installation Manual for Solid Plastic Toilet Partitions

Barrel Hinges

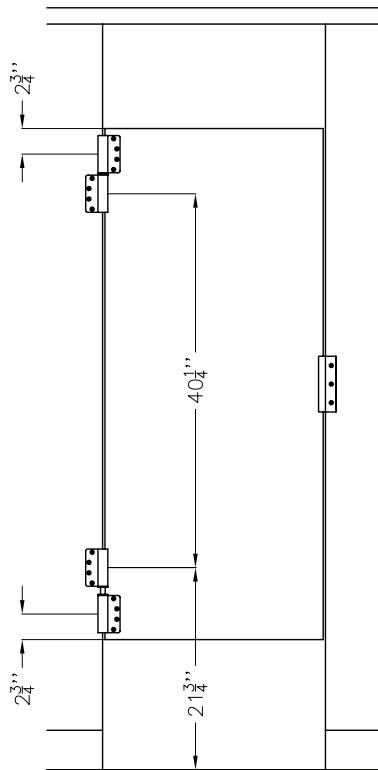
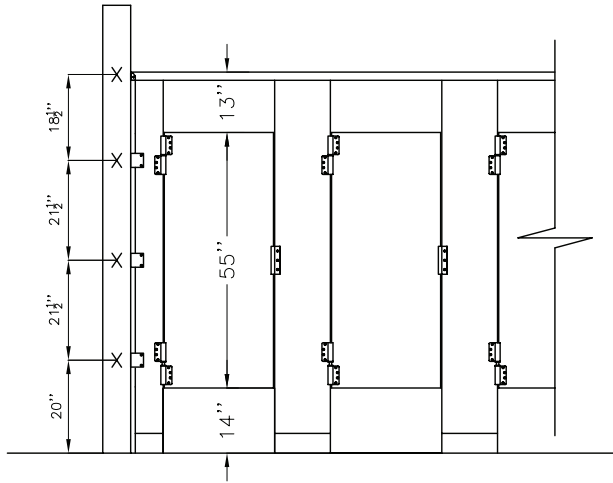

Drilling Pilot Holes for Barrel Hinges

To install the aluminum barrel hinges, pilot holes must be drilled prior to installation to ensure proper placement of the hinges.

DOORS:

2.75" in, on centerline, from the top and bottom corner of the door, drill a 1/16" diameter hole approximately 0.25" deep.

PILASTERS:

21.75" on centerline from the floor, drill a 1/16" diameter hole approximately 0.25" deep. 40.25" from the first hole drill another 1/16" diameter hole approximately 0.25" deep.



Barrel Hinges

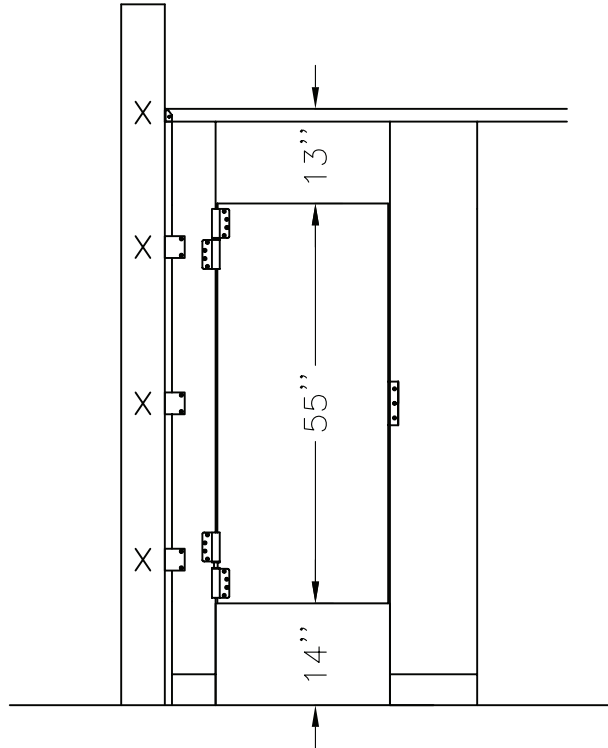

Installing Barrel Hinges

1. DRILL PILOT HOLES ON PILASTER AS INDICATED IN STEP 6 OF INSTRUCTIONS.
2. HANG PILASTER HINGES. USE HINGE AS A TEMPLATE FOR DRILLING HOLES FOR THE THROUGH-BOLTS.
(YOU MAY NEED TO REMOVE THE HINGES TO WIDEN THE HOLES FOR THE THROUGH-BOLTS)
3. ATTACH THROUGH BOLTS.
4. DRILL PILOT HOLES ON DOOR AS INDICATED IN STEP 9 OF THE INSTRUCTIONS.
5. HANG DOOR HINGES AND DRILL HOLES FOR THROUGH BOLTS AS INDICATED IN STEP 2 ABOVE.
6. SECURE UPPER DOOR HINGE ONLY WITH THROUGH-BOLTS.
7. MOUNT DOOR ON UPPER HINGE
(IT WILL BE BENEFICIAL TO HAVE A SECOND PERSON HOLD THE DOOR AS IT NOT BE SELF-SUPPORTING UNTIL THE LOWER HINGE IS INSTALLED)
8. WITH THE DOOR LEVEL AND SWUNG SLIGHTLY INWARD/OUTWARD, FROM BENEATH THE DOOR SLIDE LOWER DOOR HINGE ONTO DOOR AND ALIGN WITH THE PEG IN LOWER PILASTER HINGE. ENSURE THE CARDBOARD SPACER IS REMOVED.
9. SECURE LOWER DOOR HINGE WITH THROUGH BOLTS.



APPENDIX C - BARREL HINGES

Installation Manual for Solid Plastic Toilet Partitions

Barrel Hinges

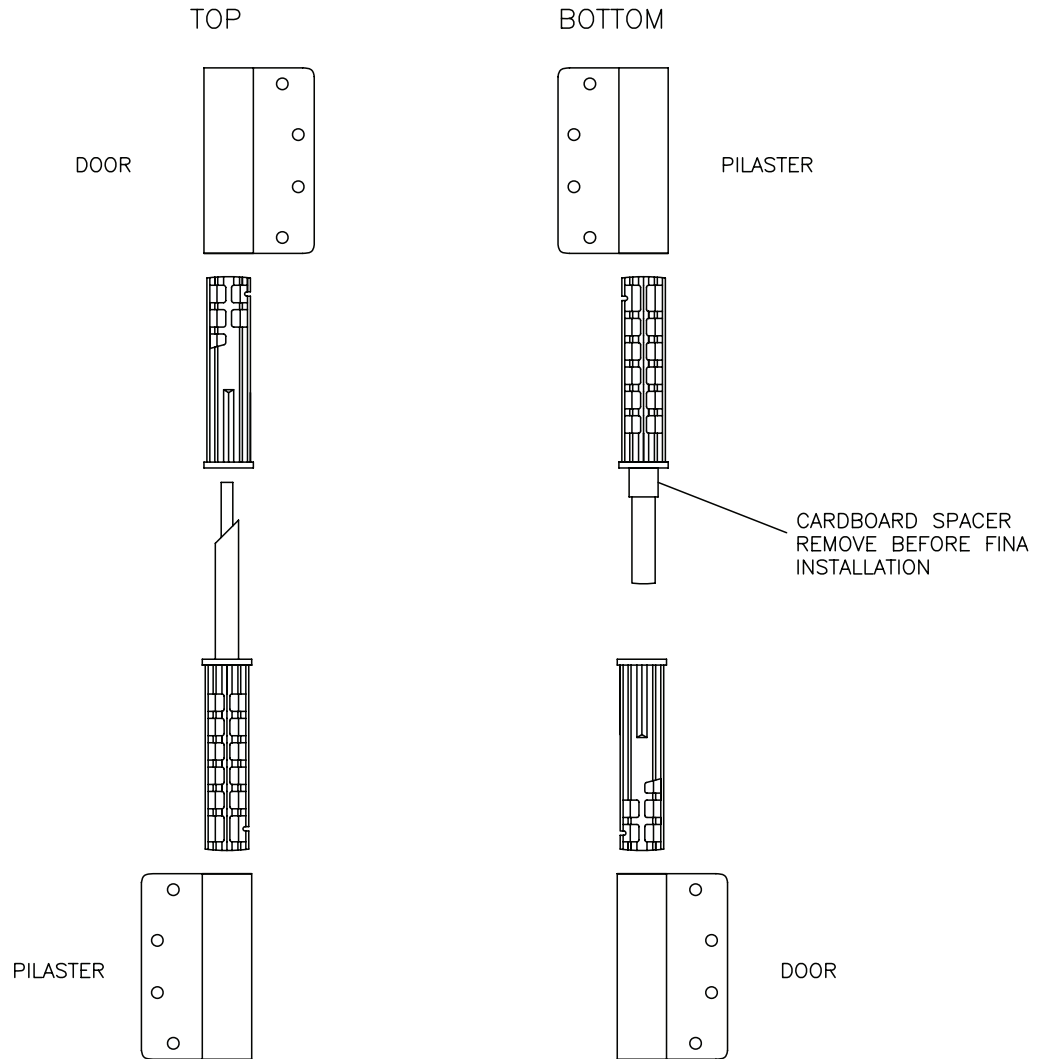



APPENDIX D - LATCH & KEEPER

Installation Manual for Solid Plastic Toilet Partitions

Installing the Latch and Keeper

1. Secure stop and keeper on pilaster at mid-point of door using through bolts.
2. Position the latch on the door, aligned with the stop and keeper as outlined below:
 - Keep latch in full extended position.
 - Position the mid-point of the latch's slide so that it is in contact with the top edge of the keeper's slot.
3. Secure the latch to the door using through bolts.

Surface Latch

(shown in fully extended position)

Stop and Keeper

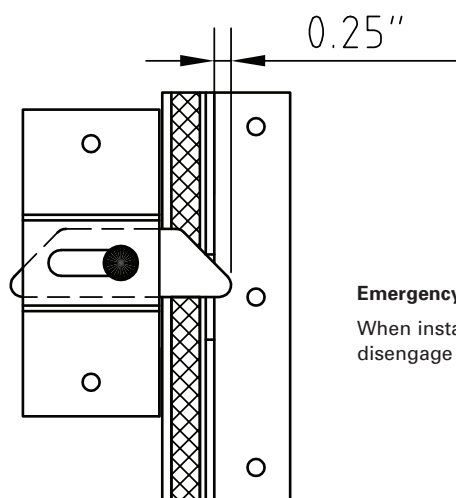
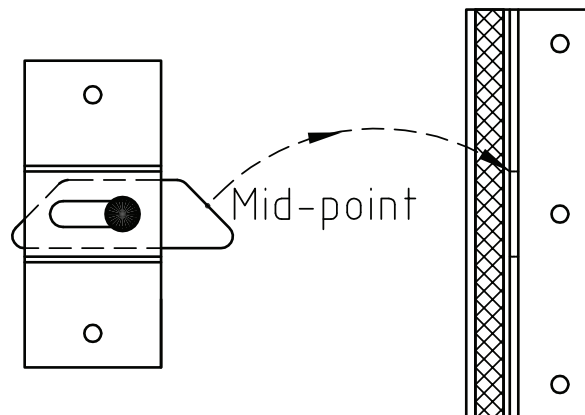

Emergency Access

When installed correctly (as shown here), lifting the door will disengage the latch to allow access in case of an emergency.



APPENDIX E - CONTINUOUS HINGES

Installation Manual for Solid Plastic Toilet Partitions

Continuous Hinges

Continuous hinges are through bolted as shown below using barrel nuts (620123) and 1" barrel screws (620124).

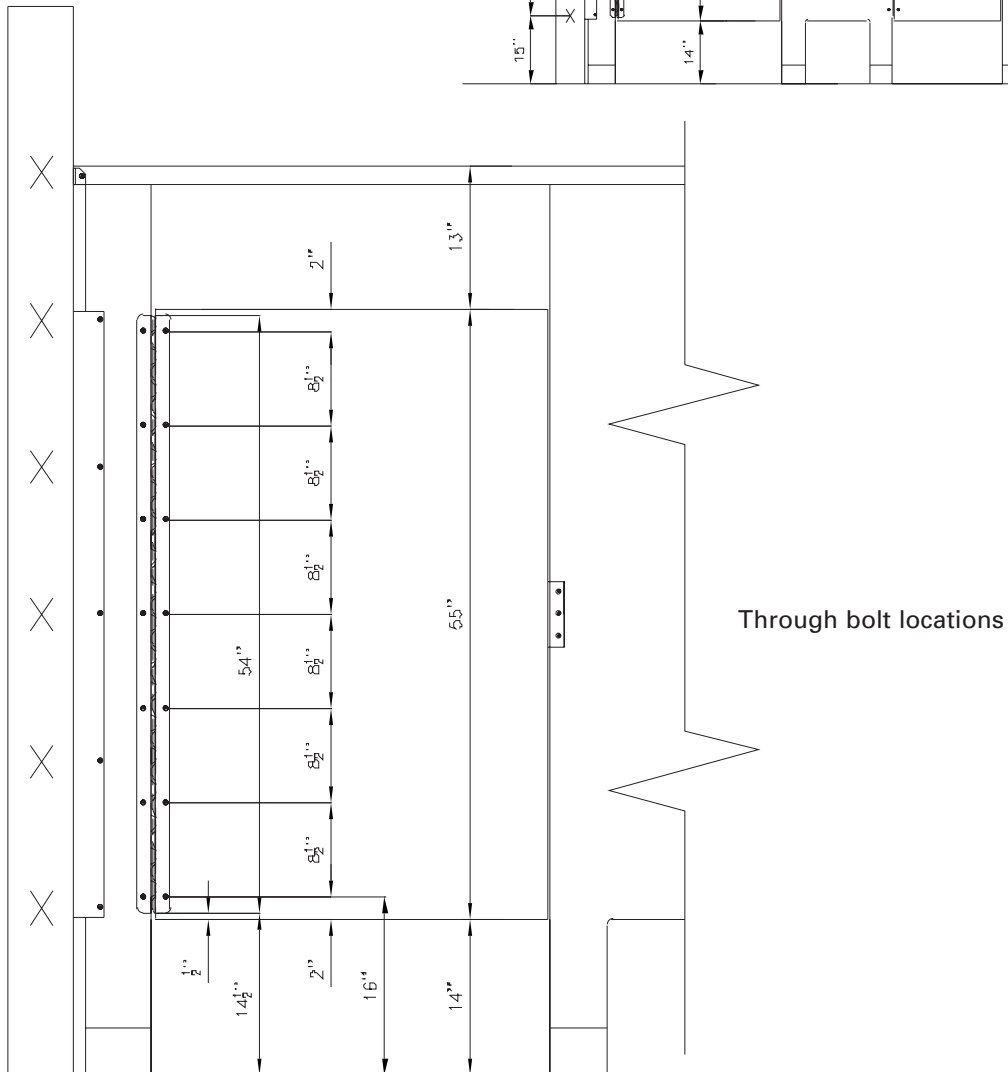
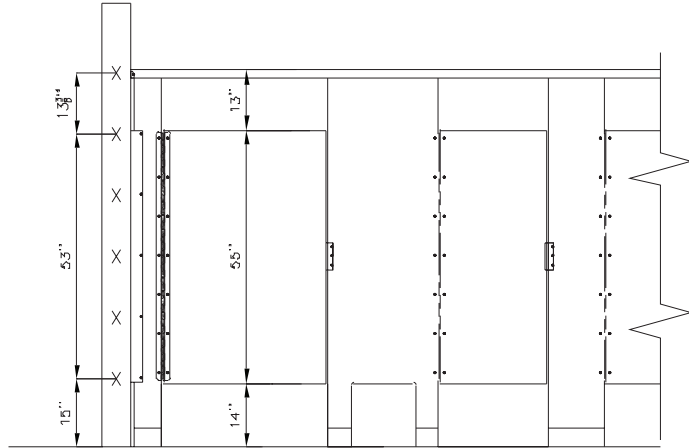



APPENDIX F - INTEGRAL HINGES

Installation Manual for Solid Plastic Toilet Partitions

Installation Details for Integral Hinges

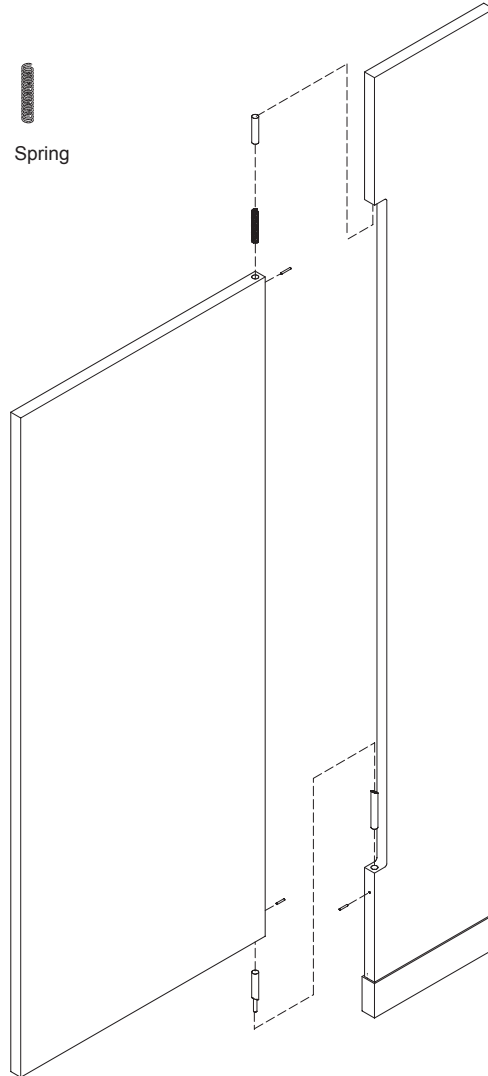
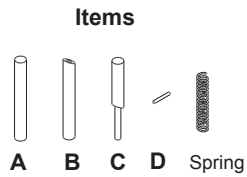

Bottom of integral hinge door is identified by a small hole located beside the hinge hole.



Continued on next page.



APPENDIX F - INTEGRAL HINGES

Installation Manual for Solid Plastic Toilet Partitions

1

Insert male cam (item C) into bottom hole in door. Drill a 3mm (1/8") hole through pilot hole on the door and into the male cam. Partially insert locking pin (item D), leaving 3mm (1/8") exposed to allow for removal or readjustment if necessary.

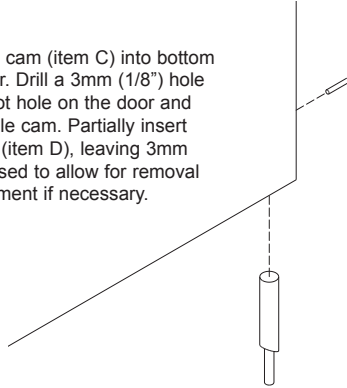

2

Insert female cam (item B) into lower hole in pilaster and adjust for desired door swing. Drill a 3mm (1/8") hole through pilot hole in pilaster and into the female cam. Partially insert locking pin, leaving 3mm (1/8") exposed.

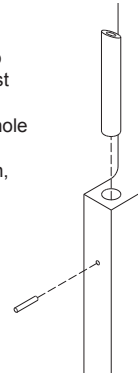

3

Insert spring into top of door.

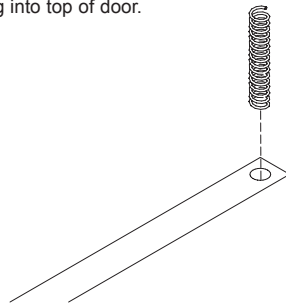

4

Insert door pin (item A) into top hole of door.

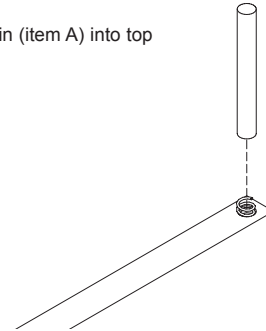

5

Insert the male cam at the bottom of door into the female cam in the pilaster. While depressing the door pin into the top of the door, line up the door and pilaster until the door pin slides into the pilaster.

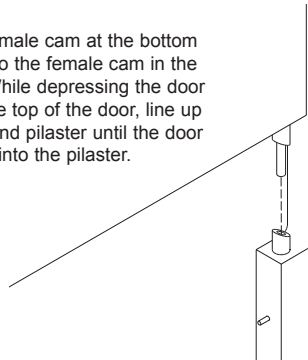

6

Drill a 3mm (1/8") hole through pilot hole in door and into the door pin. Partially insert locking pin, leaving 3mm (1/8") exposed.

Test door to ensure proper operation. If no further adjustment is required, drive all locking pins fully into place.

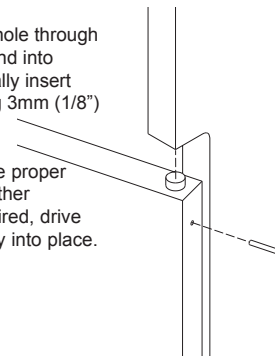



APPENDIX G - ALCOVE PILASTERS

Installation Manual for Solid Plastic Toilet Partitions

Alcove Pilasters

Standard alcove pilaster sizes are 24", 30" and 36". A full range of sizes in one inch increments between 21" and 36" is available upon request.

Regardless of pilaster width, alcove pilasters always use two 8" shoes.

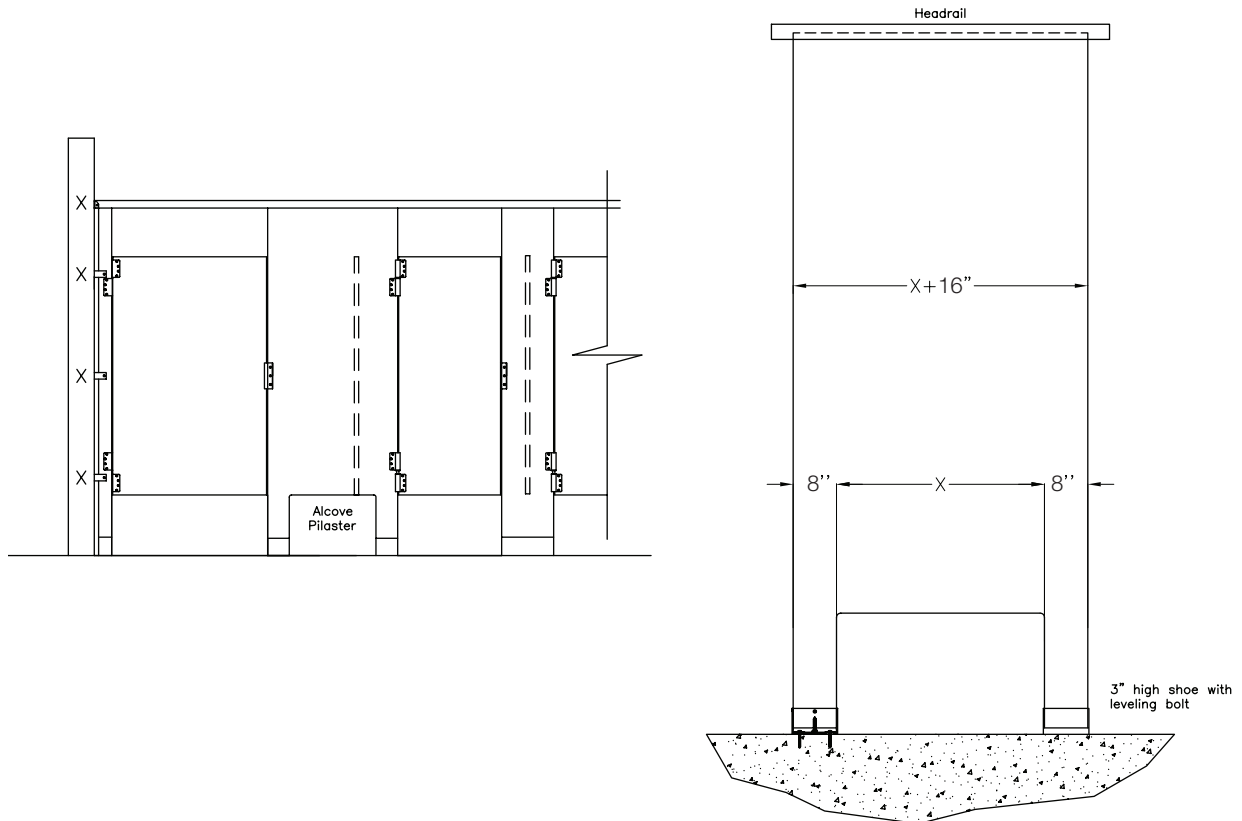



APPENDIX H - CEILING HUNG

Installation Manual for Solid Plastic Toilet Partitions

Ceiling Connection

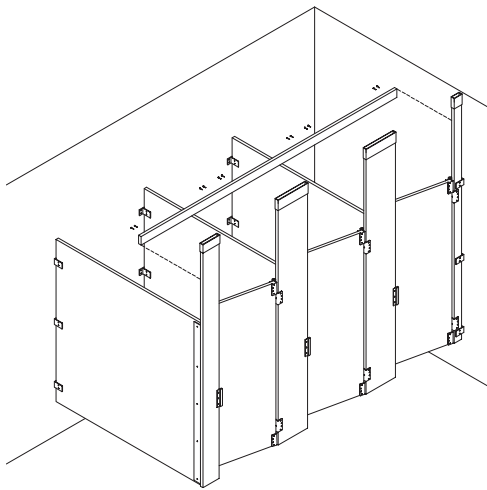
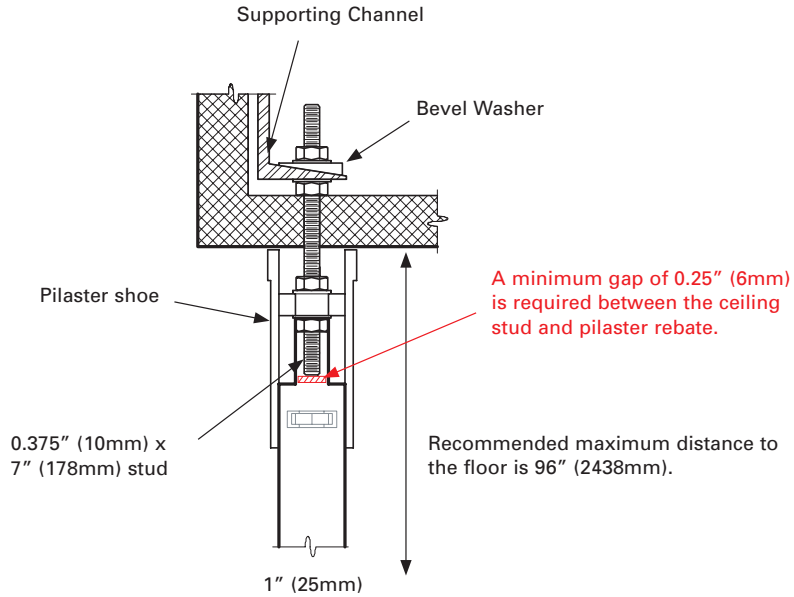

Stabilizer Bar for Ceiling Hung Partitions

Ceiling hung installations require a stabilizer bar to be fastened horizontally across the back of the pilasters, 7 feet (2134mm) above the floor. The stabilizer bar should be fastened with one or two screws per pilaster (depending on the size of the pilaster) on the inside of the unit.



APPENDIX I - FLOOR TO CEILING

Installation Manual for Solid Plastic Toilet Partitions

Ceiling Connection

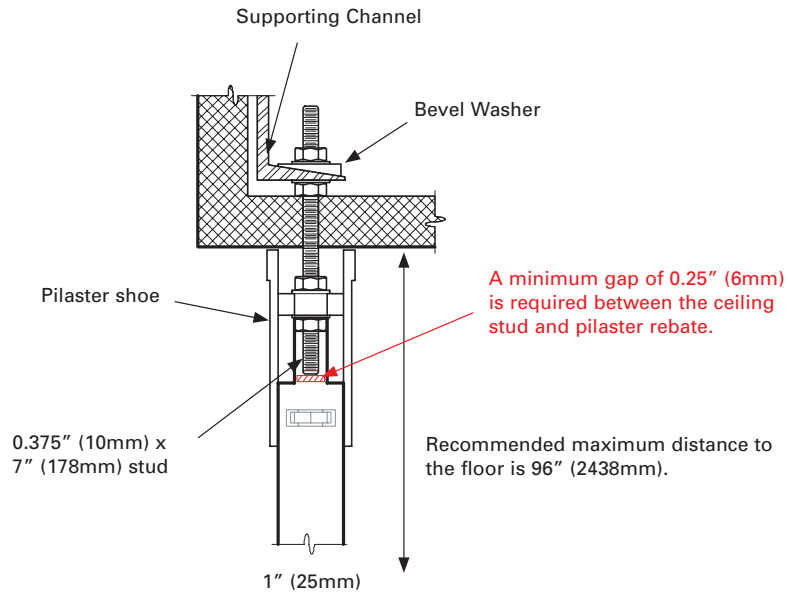

Floor Connection

